

Slot to Slot Connections
Washers are required on both sides of material if slots are used on both sides.

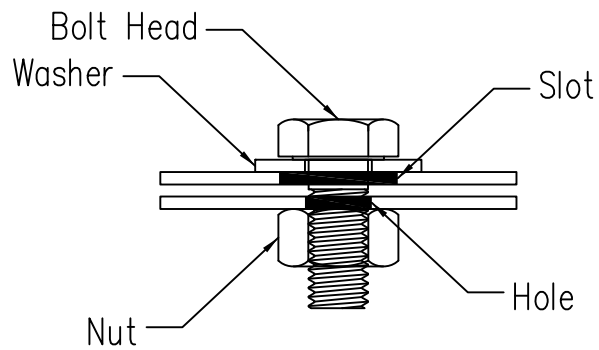

Slot to Hole Connections
One washer required on slotted side only.

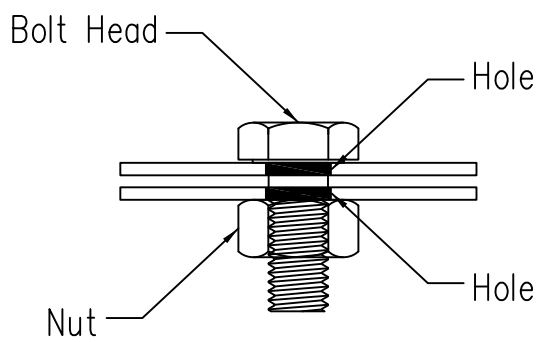

Hole to Hole Connections
No washers are required when slots are not used.

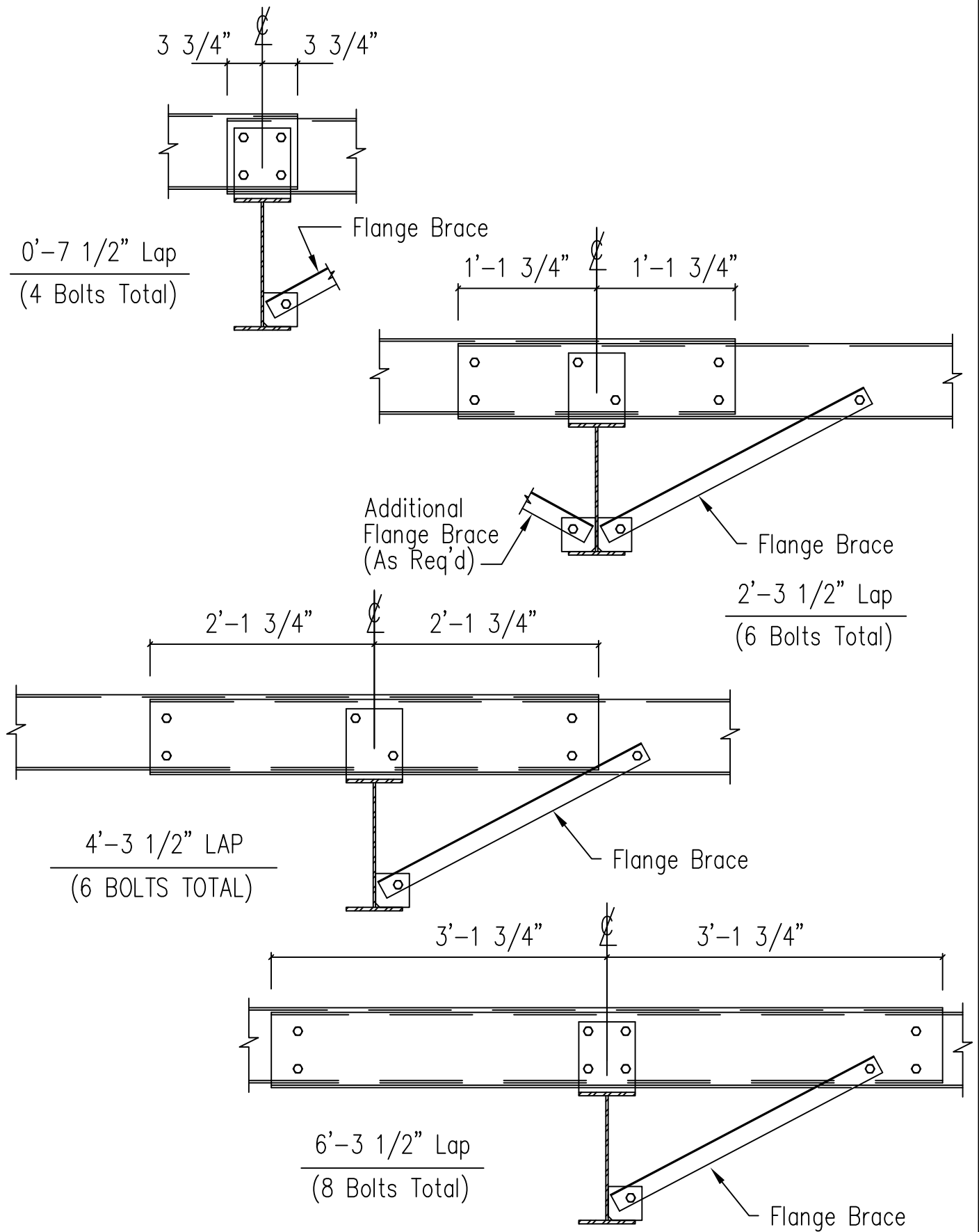

Note: All connection bolts are 1/2" x 1 1/4" machine bolts unless noted.

Interior Bay Purlin Framing

DRAWING NO.

SD50

Additional
Flange Brace
(As Req'd)

Flange Brace

Flange Brace

3 3/4" | 3 3/4"

0'-7 1/2" Lap
(4 Bolts Total)

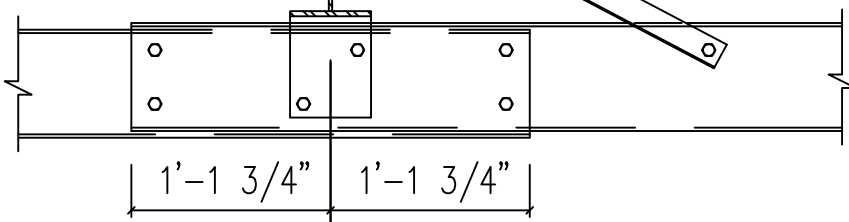

2'-3 1/2" Lap
(6 Bolts Total)

4'-3 1/2" LAP
(6 BOLTS TOTAL)

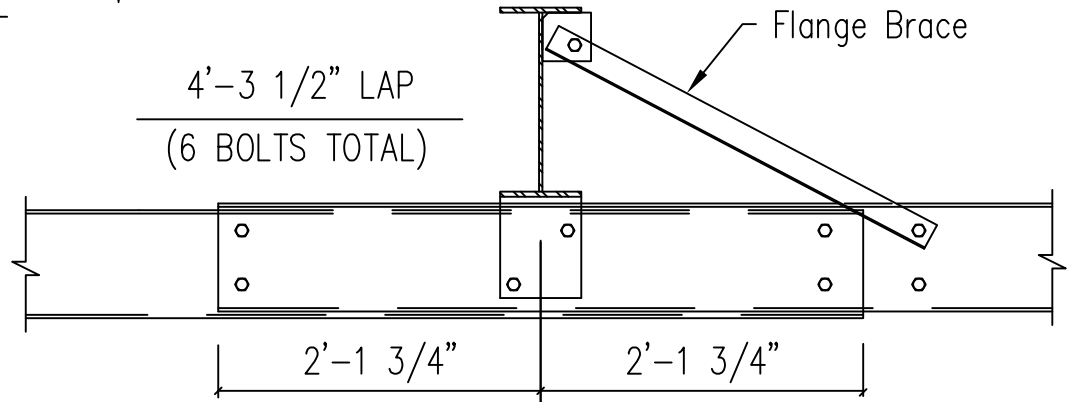

6'-3 1/2" Lap
(8 Bolts Total)

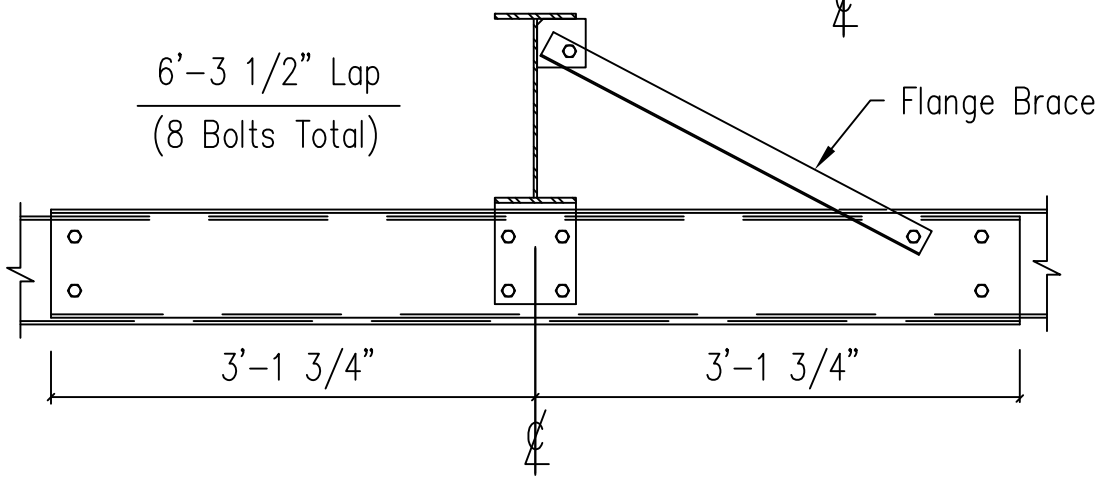

Note: All connection bolts are 1/2" x 1 1/4" machine bolts unless noted.

Interior Bay Girt Framing

DRAWING NO.

SD51