

Section Thru Rake at Cold-Form Rafter

DRAWING NO.

SD1

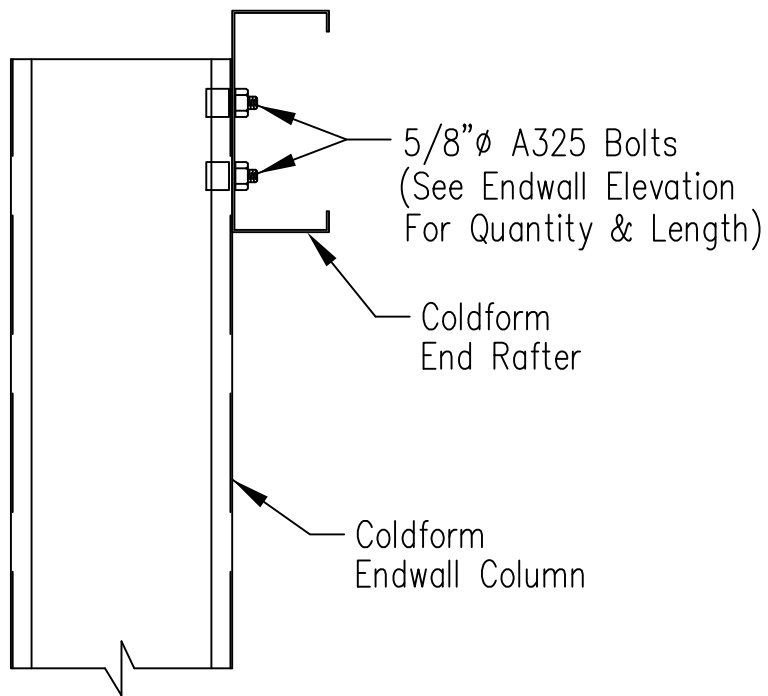
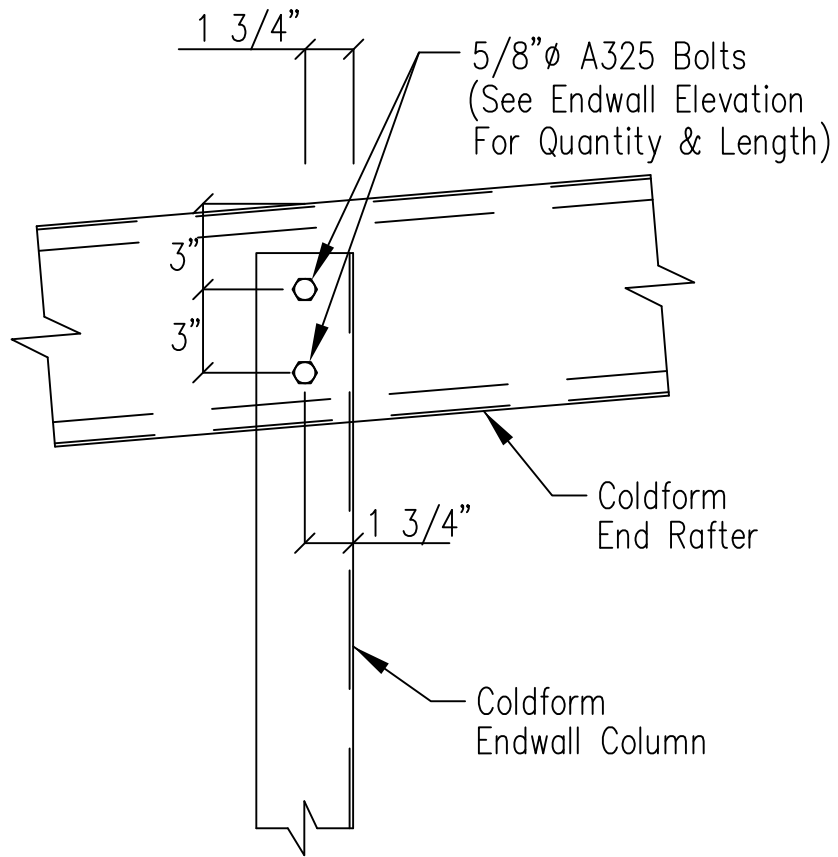

Cold Form Column to Cold Form Rafter

DRAWING NO.

SD2

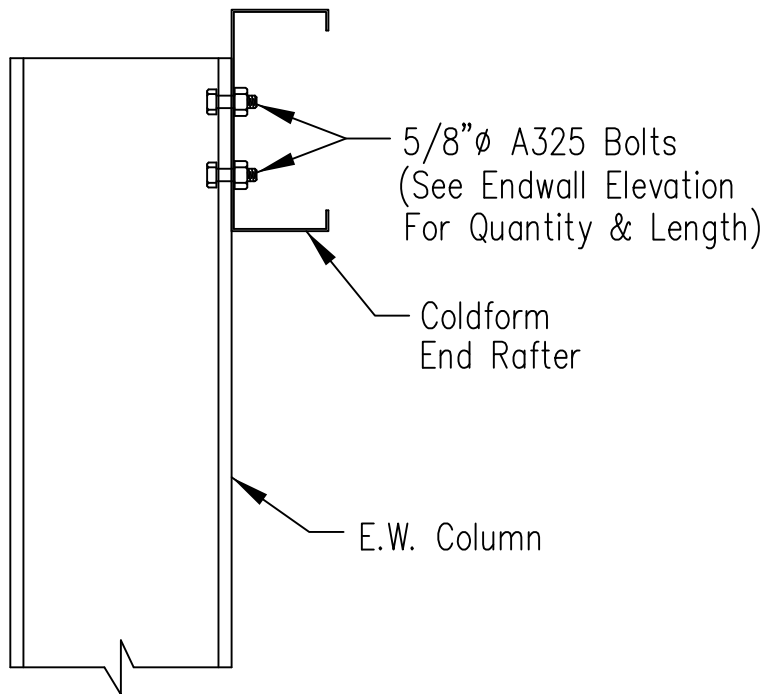
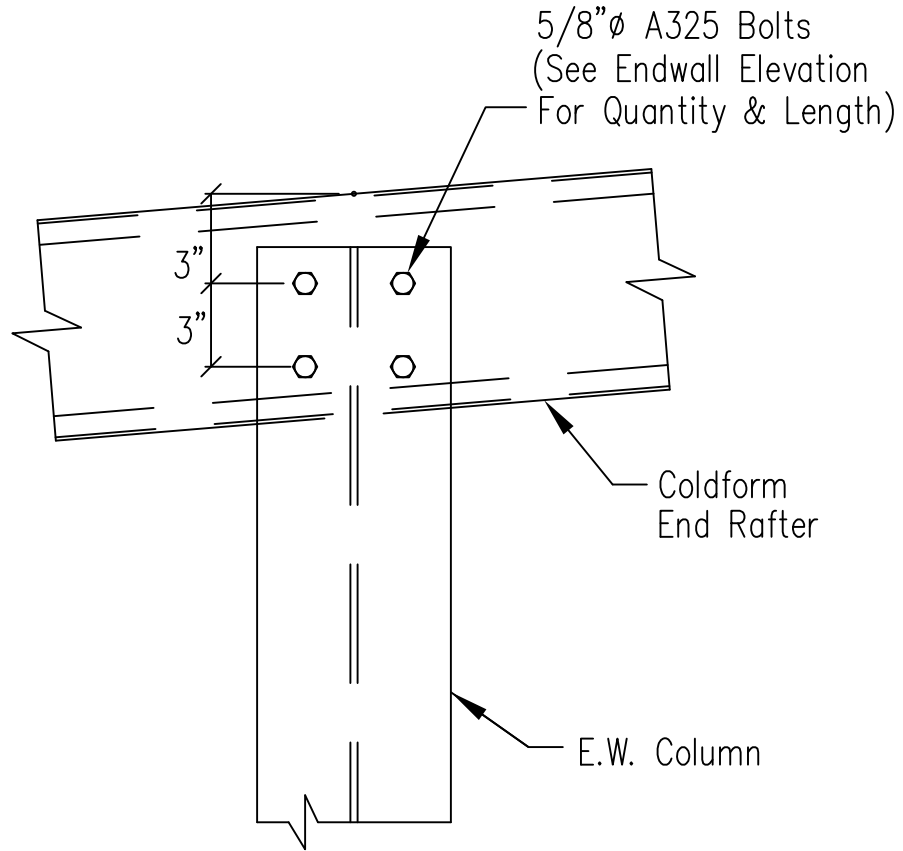

Hot Rolled Column to Cold Form Rafter

DRAWING NO.

SD3

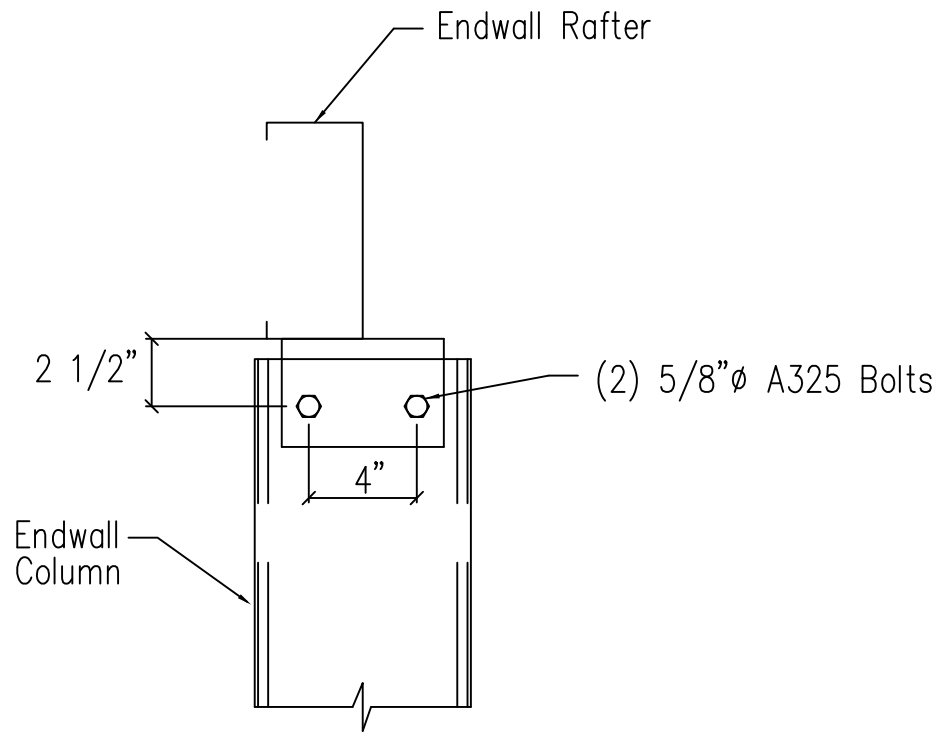
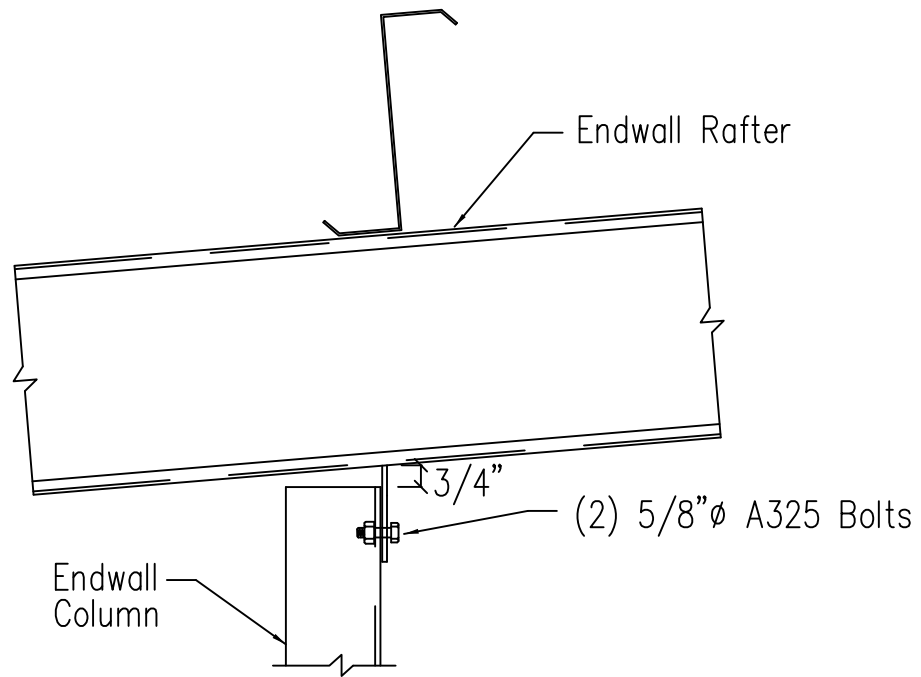

Cold Form Column to Cold Form Rafter

DRAWING NO.

SD4

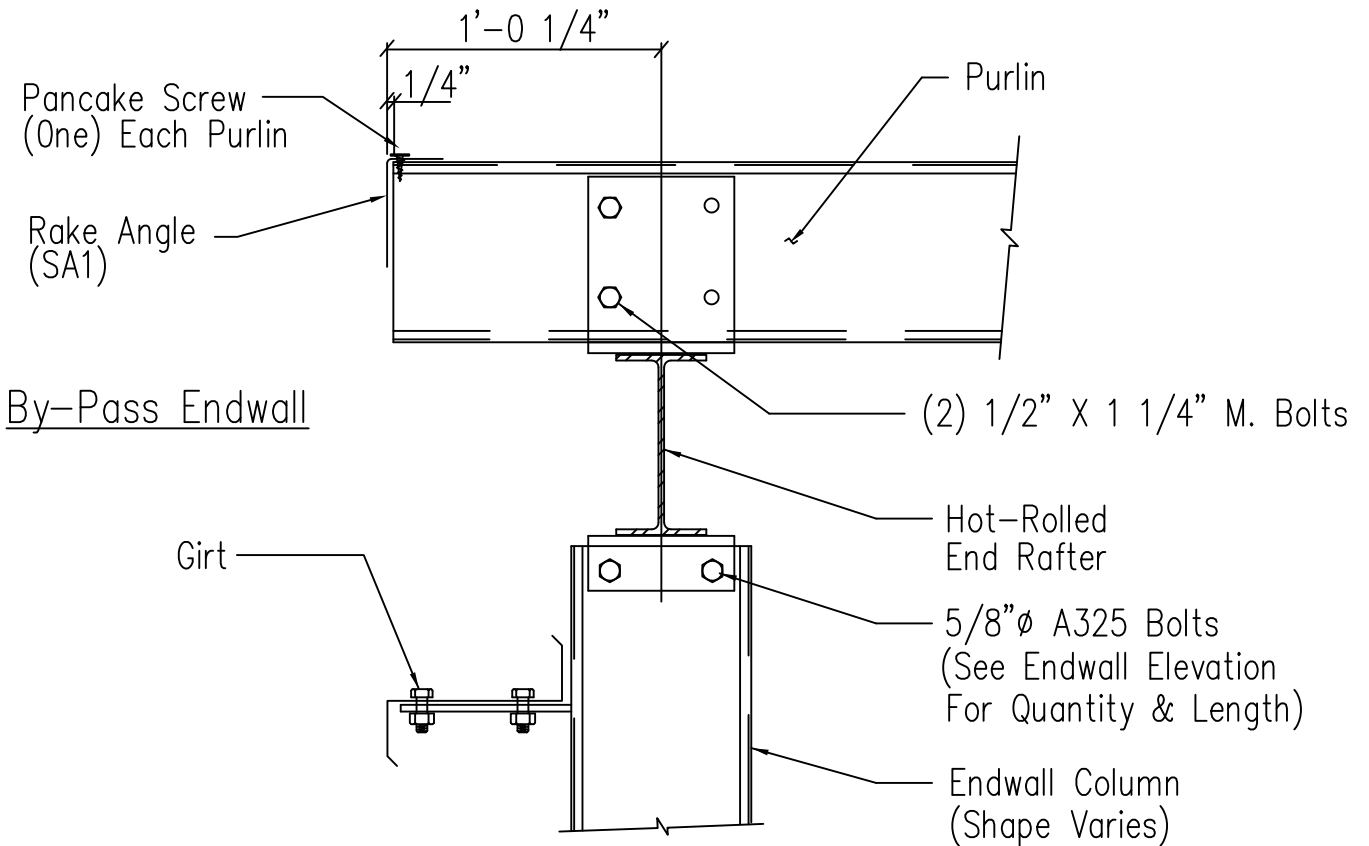
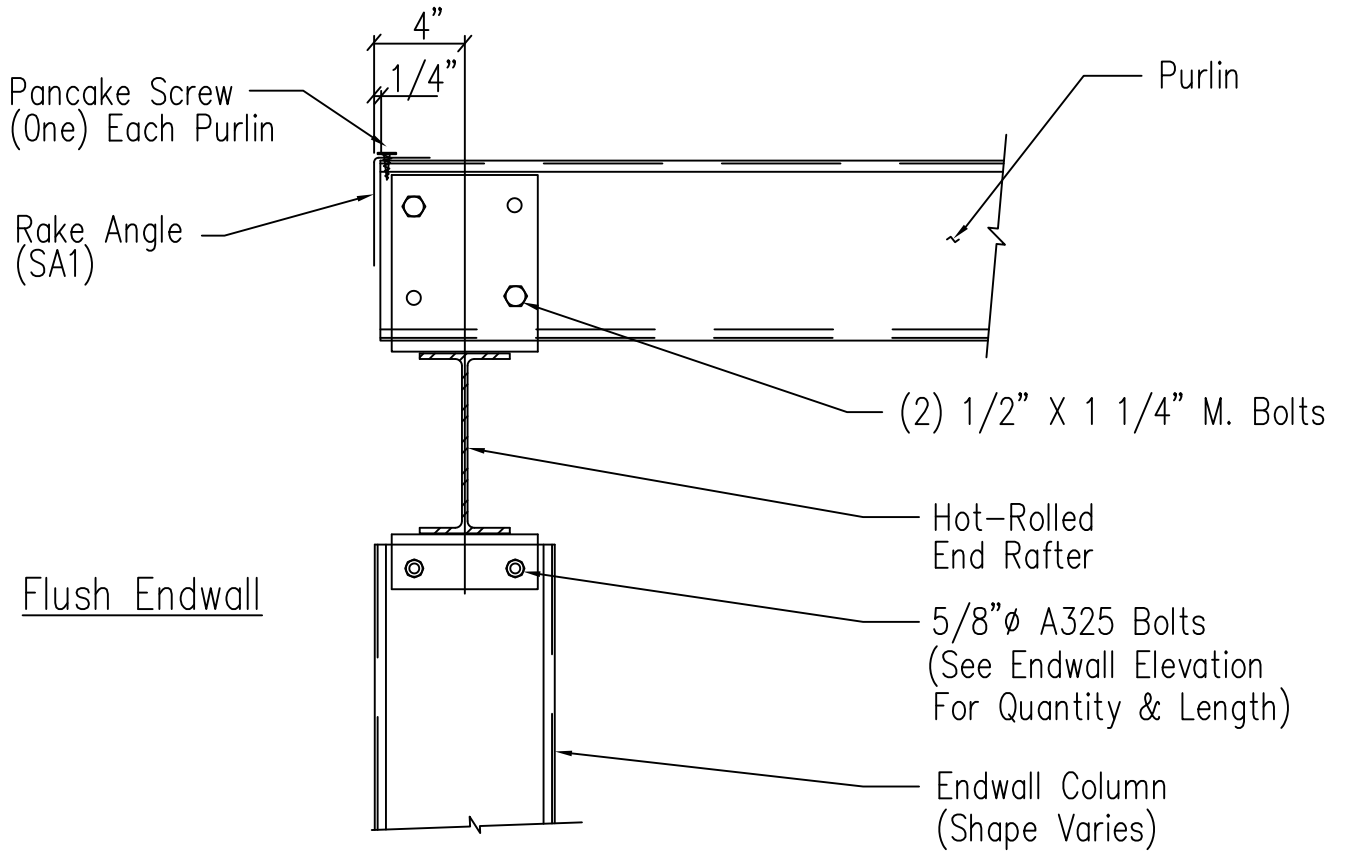

Section Thru Rake w/Hot Rolled Rafter

DRAWING NO.

SD5

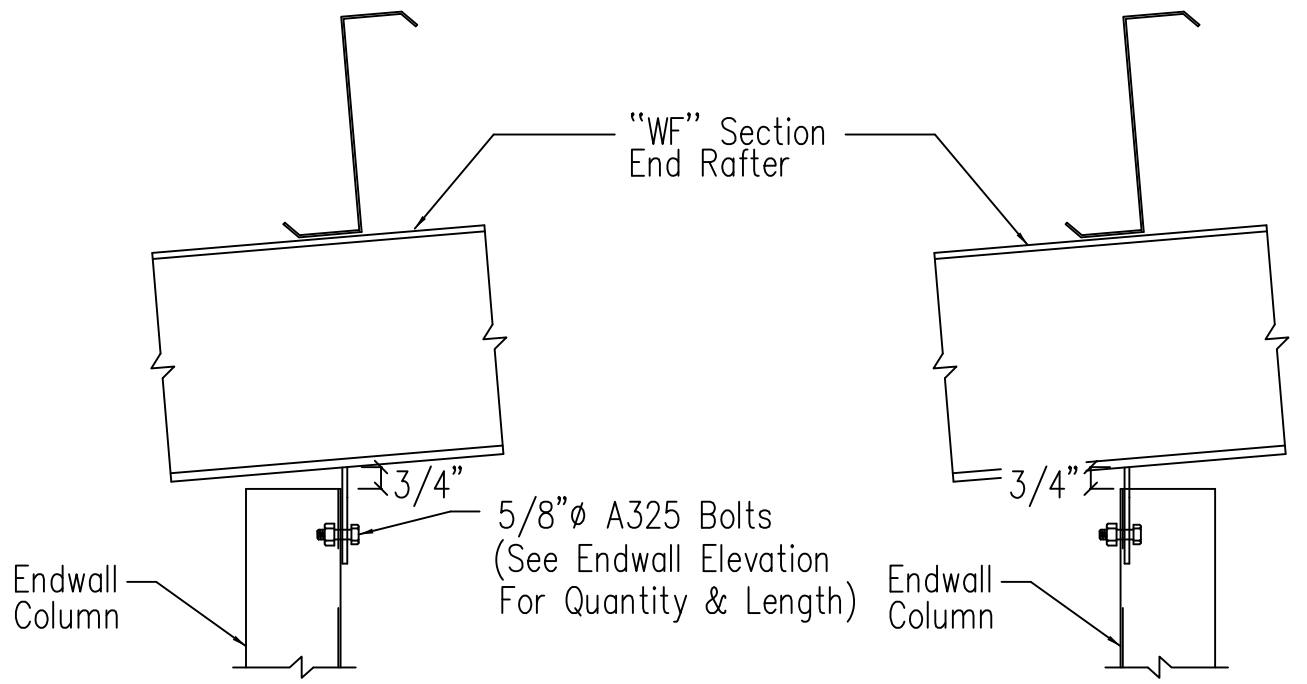

Cee Endwall Column  
Toes Toward Downslope

Cee Endwall Column  
Toes Toward Upslope

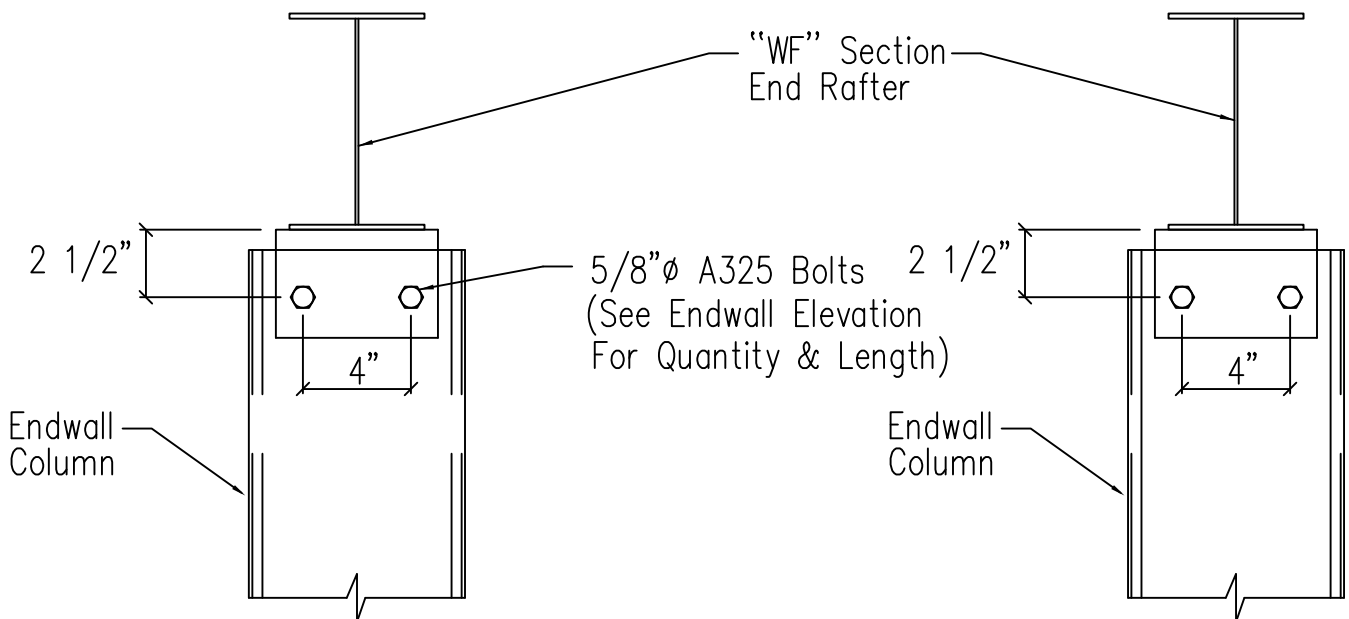

Cold Form Column to Hot Rolled Rafter

DRAWING NO.

SD6

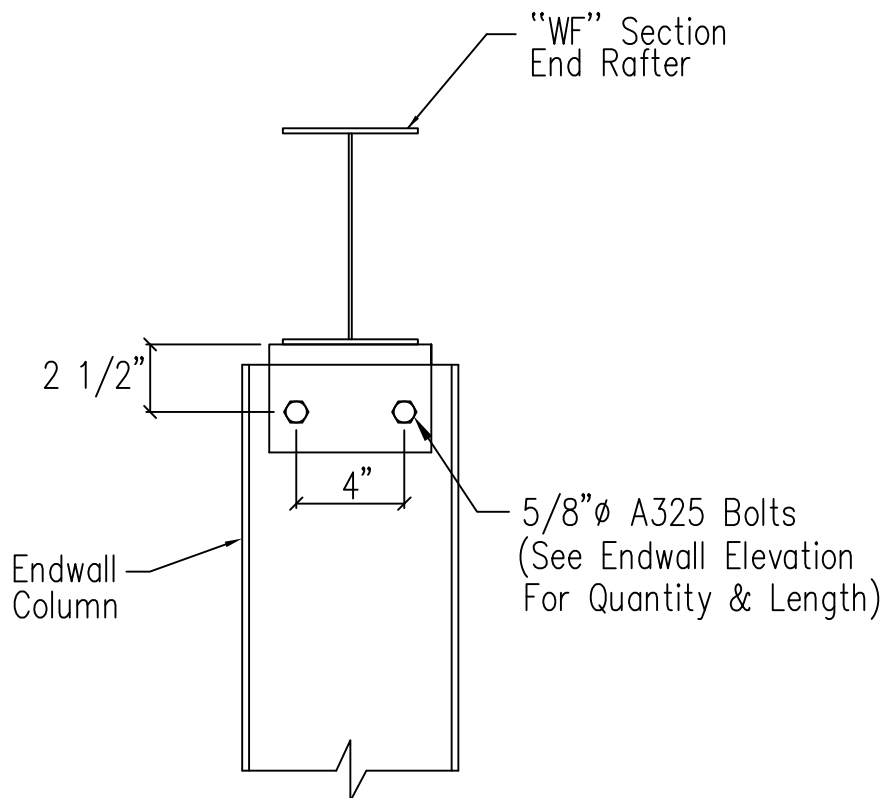
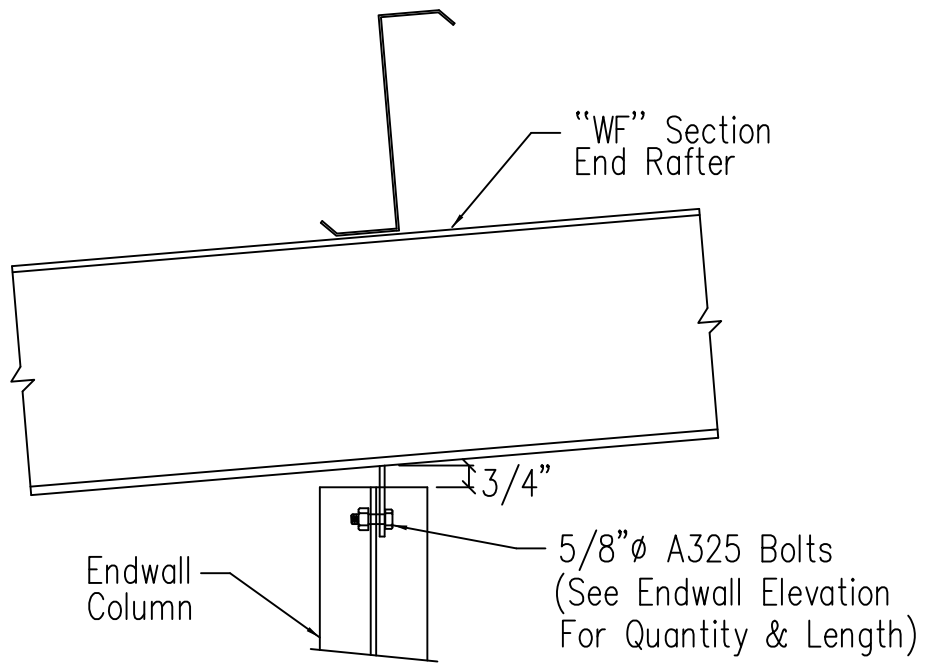

Hot Rolled Column to Hot Rolled Rafter

DRAWING NO.

SD7

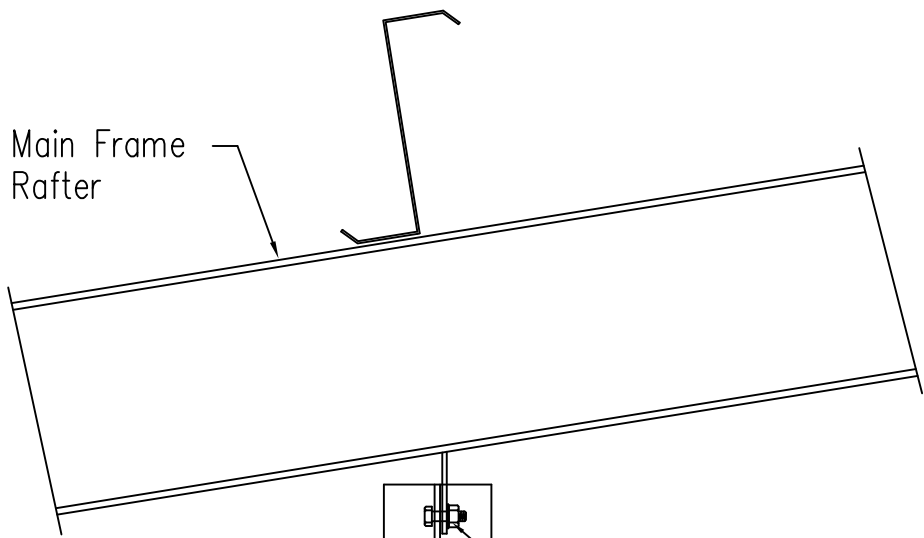

Main Frame Rafter

Interior Column

5/8"  $\phi$  A325 Bolts  
(See Endwall Elevation  
For Quantity & Length)  
w/ Flat Washers

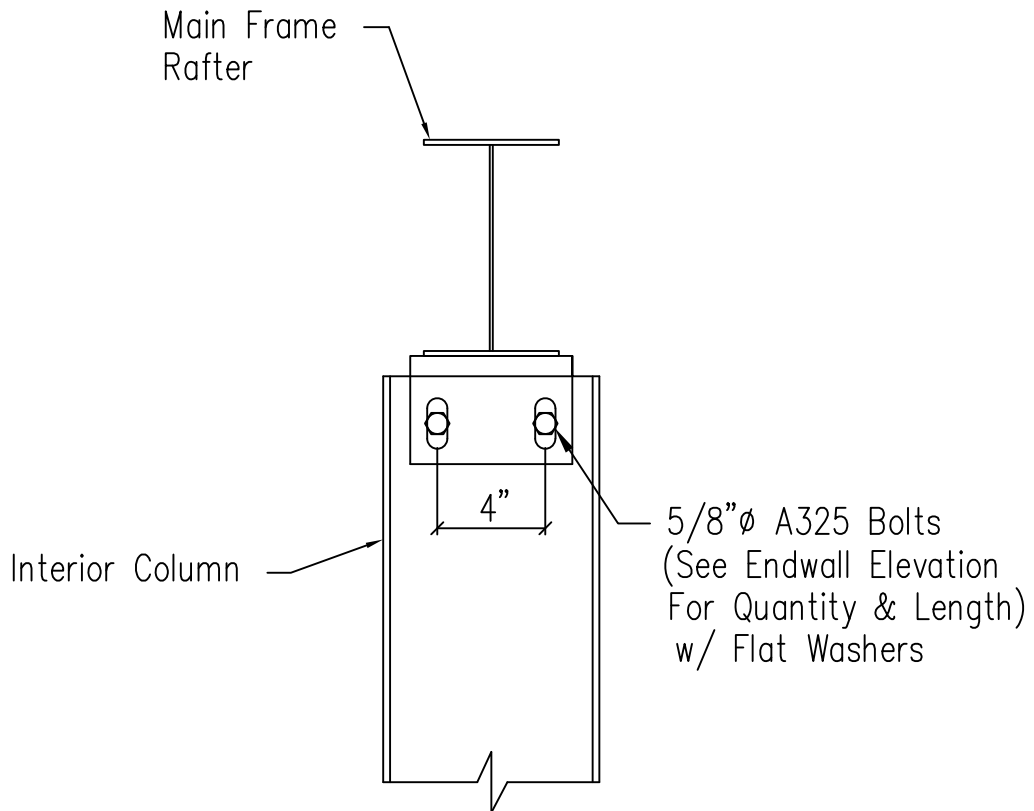

Main Frame Rafter

Interior Column

5/8"  $\phi$  A325 Bolts  
(See Endwall Elevation  
For Quantity & Length)  
w/ Flat Washers

4"

# Hot Rolled Column to Main Frame Rafter

DRAWING NO.

SD8



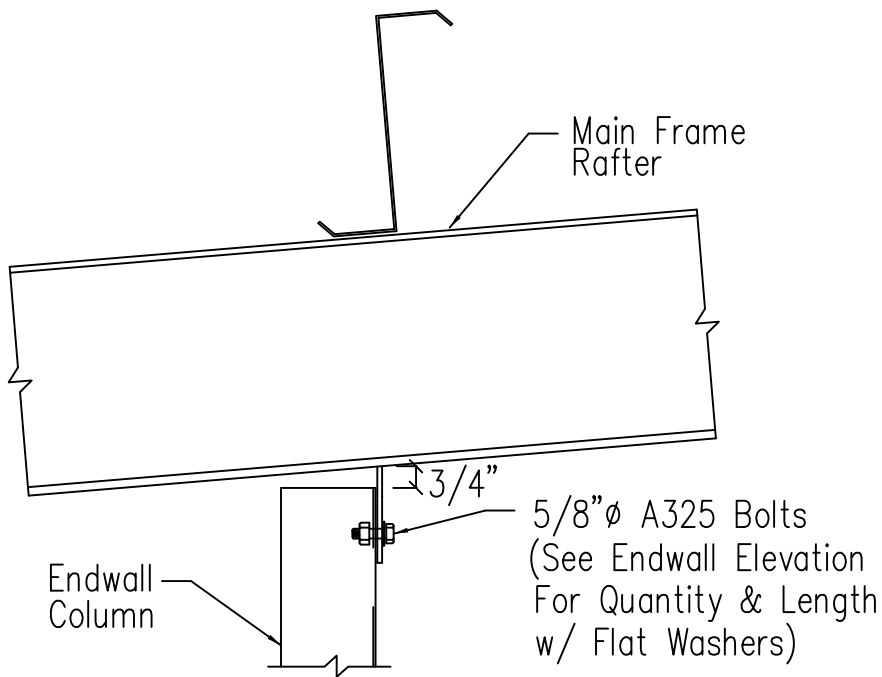

Cee Endwall Column  
Toes Toward Downslope

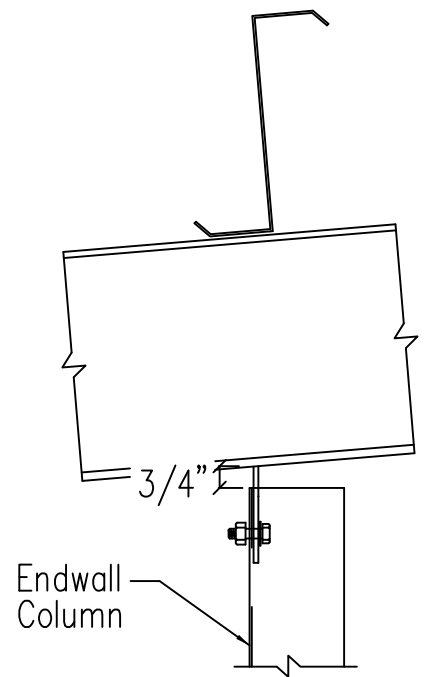

Cee Endwall Column  
Toes Toward Upslope

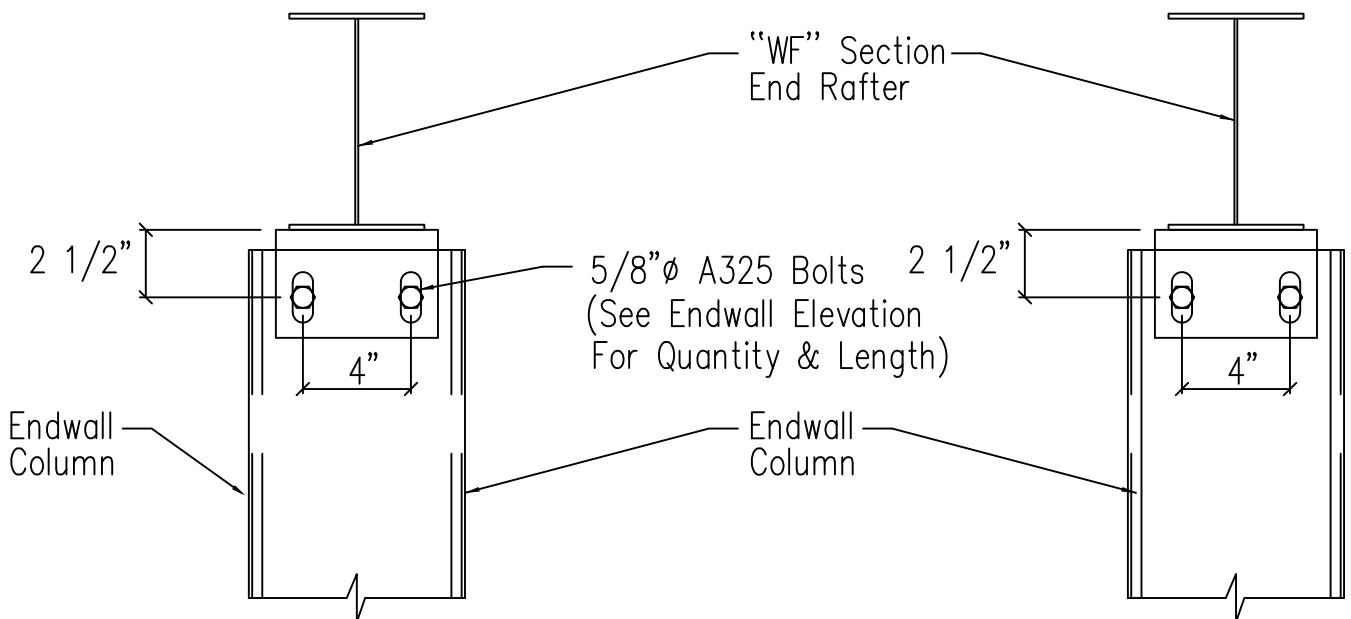

Cold Form Column to Main Frame Rafter

DRAWING NO.

SD8

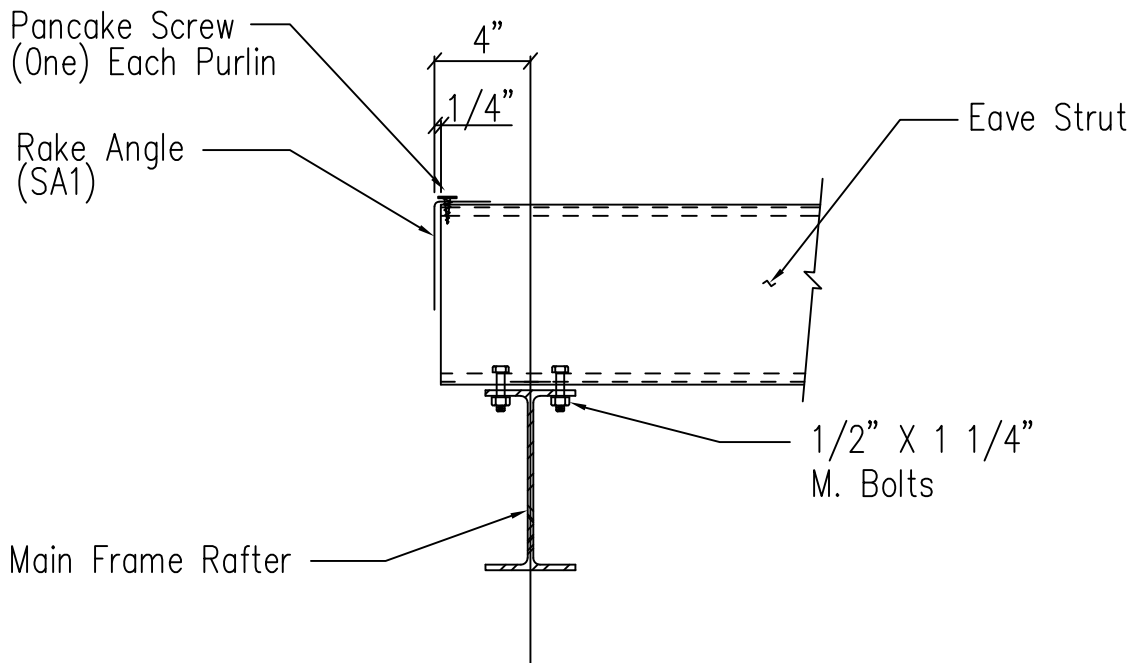
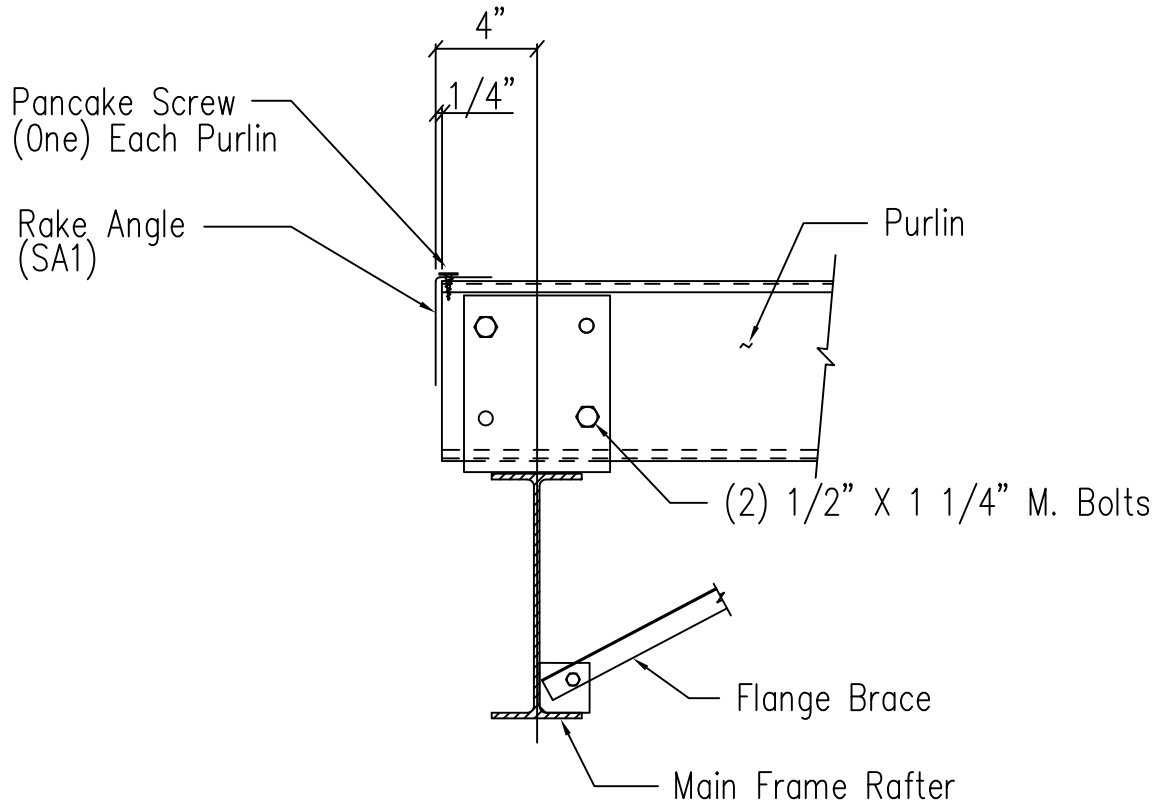

Main Frame Rafter Connection  
 PURLIN & EAVE STRUT CONNECTION

DRAWING NO.

SD9

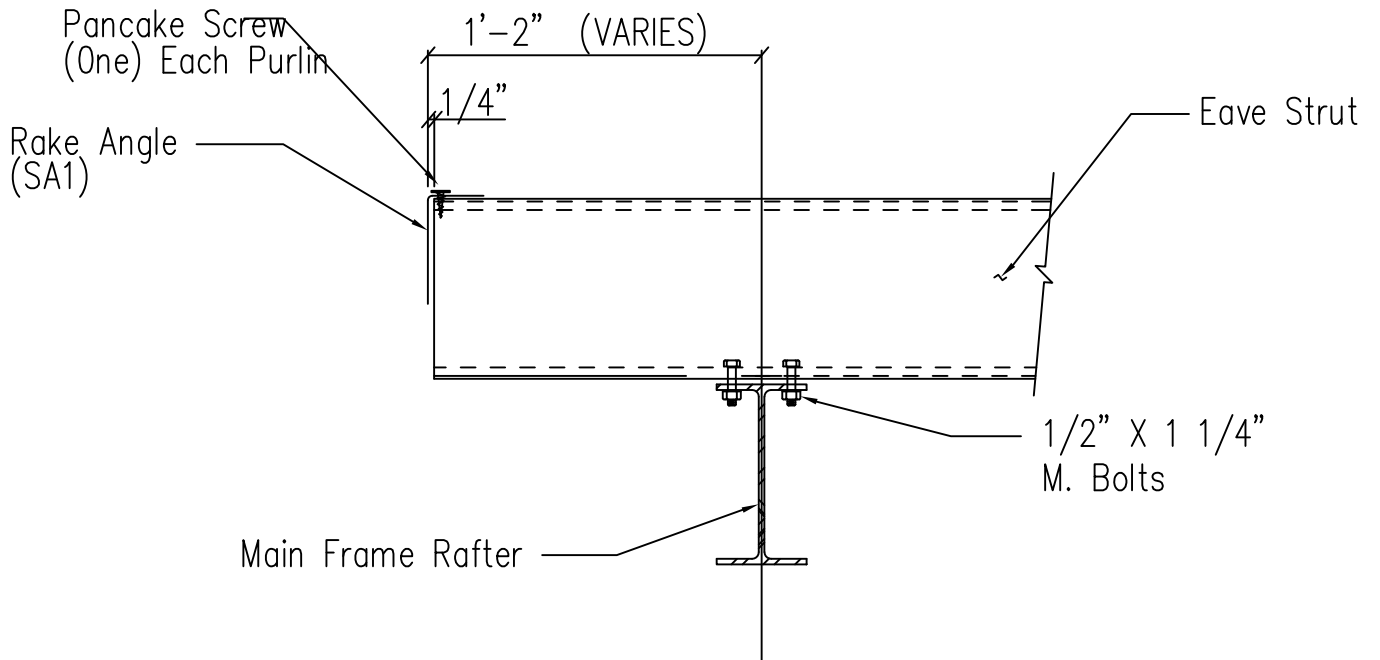
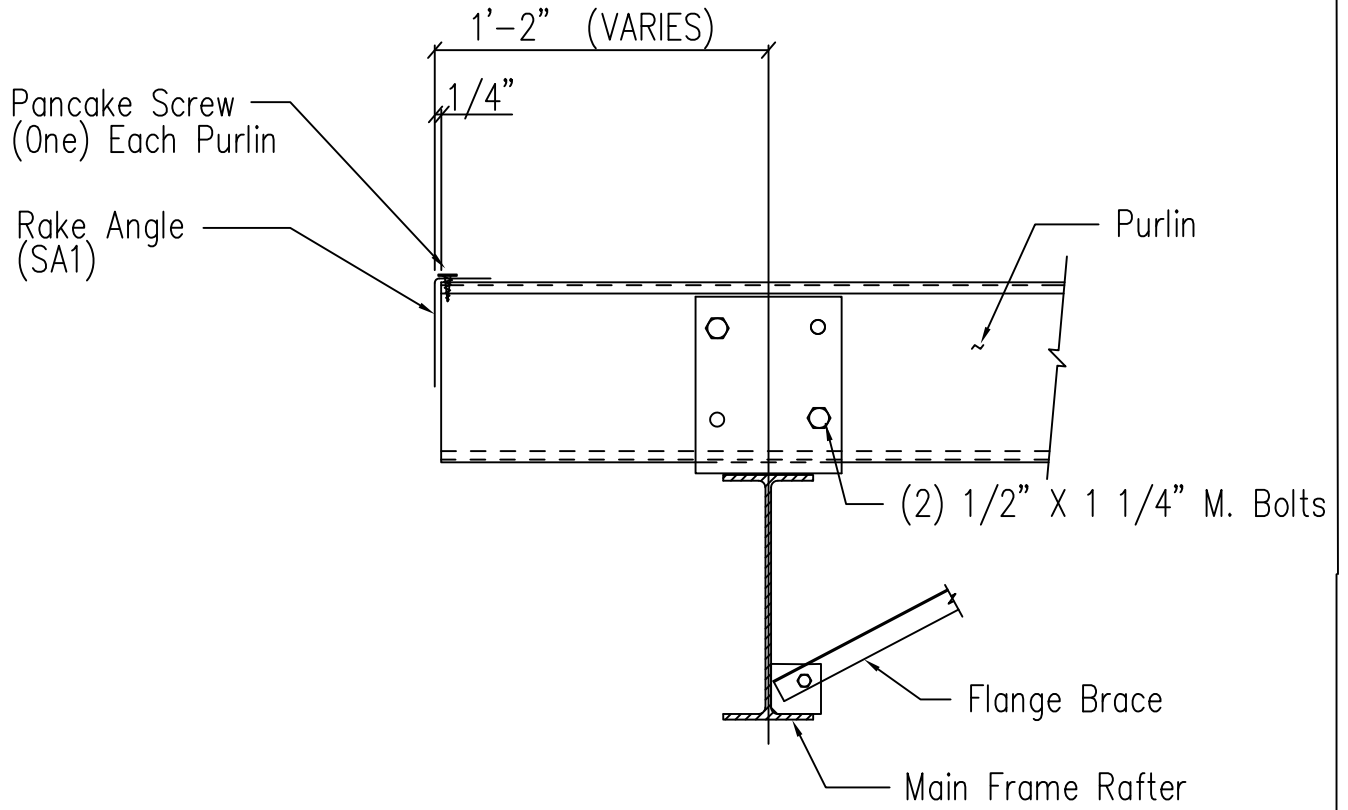

**Main Frame Rafter Connection**  
 PURLIN & EAVE STRUT CONNECTION

DRAWING NO.  
**SD10**

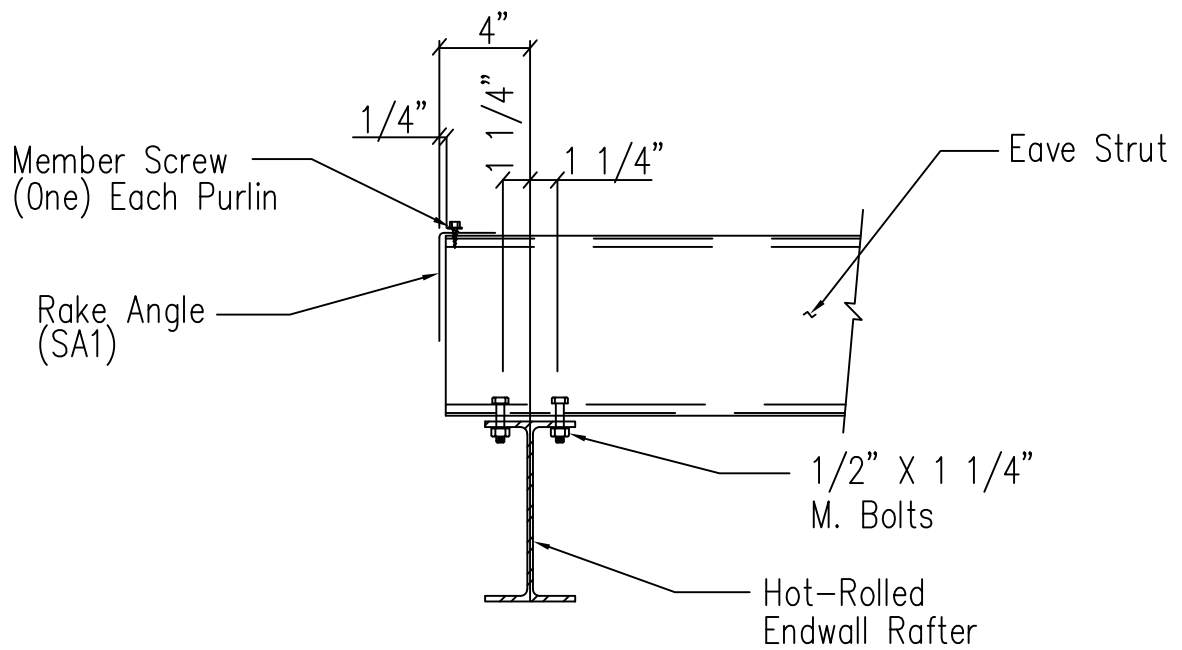
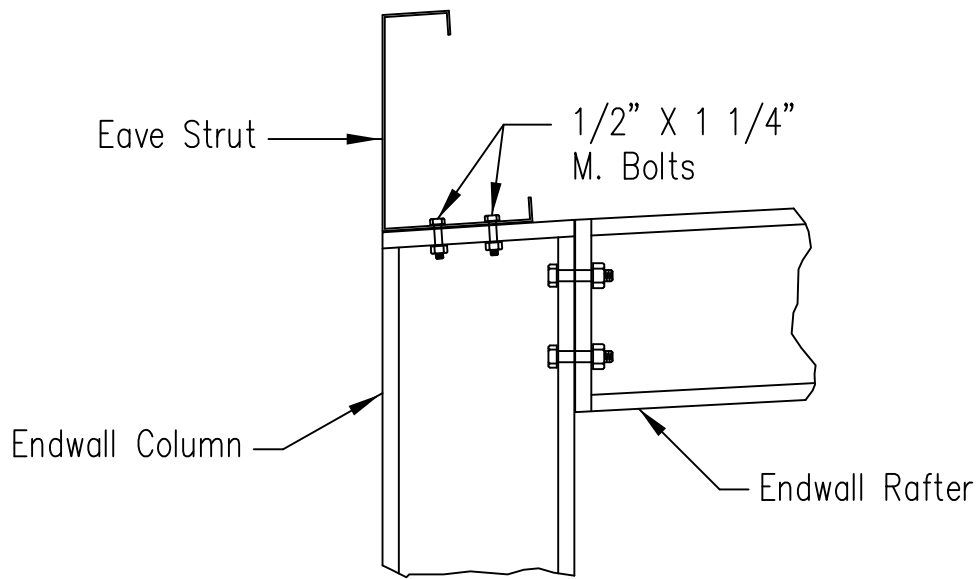

Corner Column Connection WF Rafter/Column  
 Flush Sidewall

DRAWING NO.  
 SD12

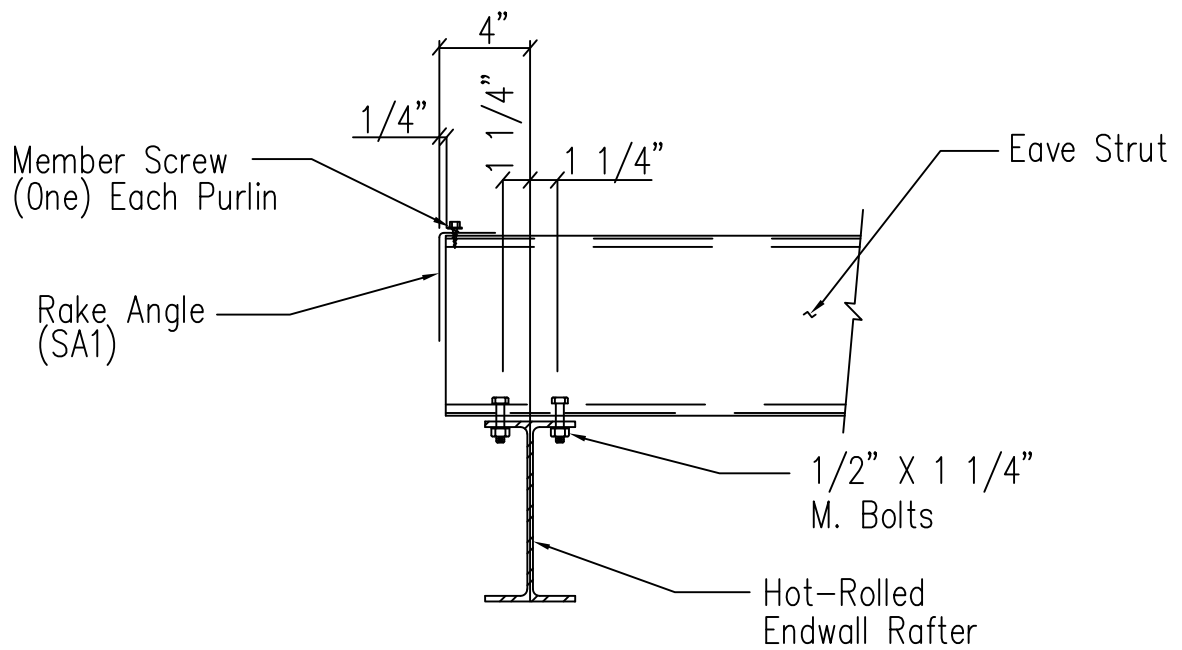
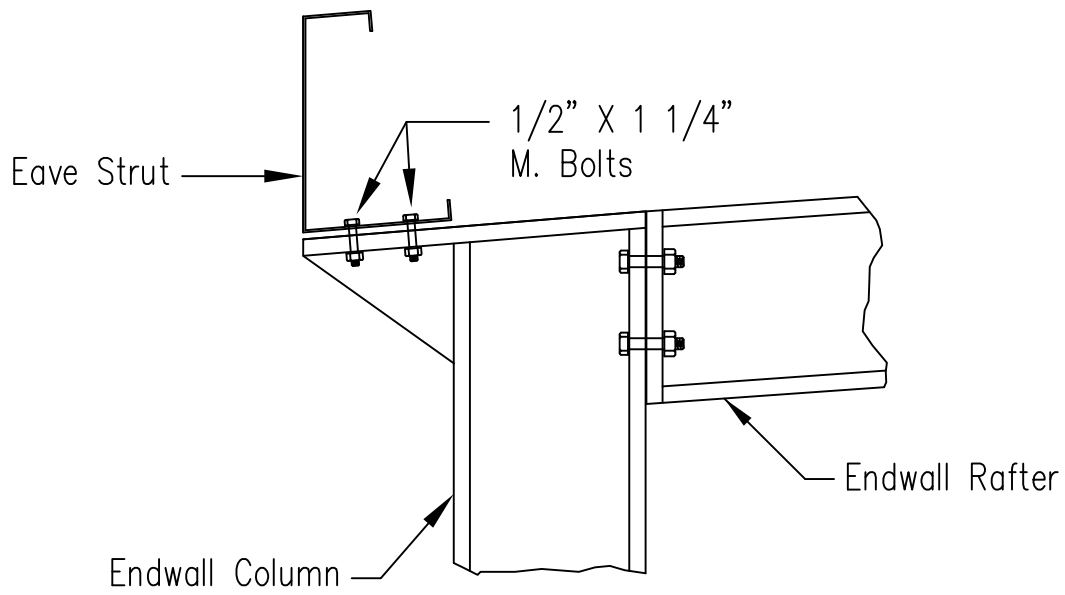

Corner Column Connection WF Rafter/Column  
By-Pass Sidewall

DRAWING NO.

SD13

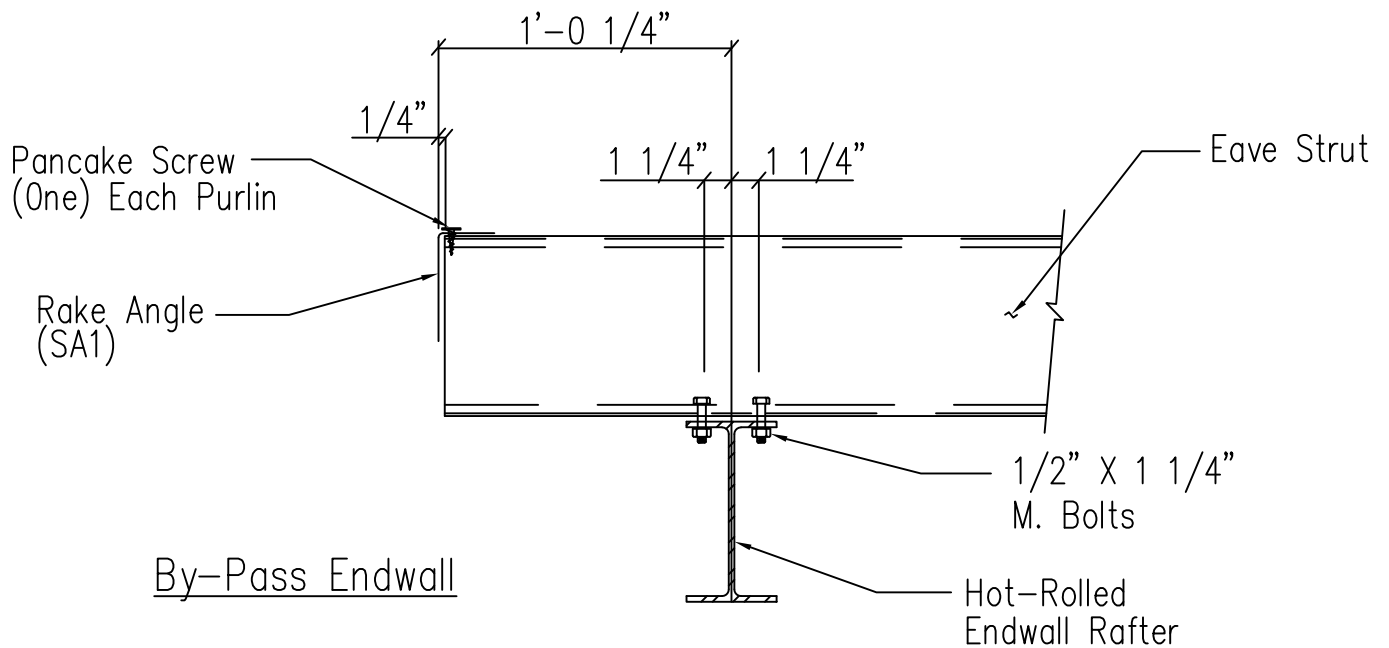
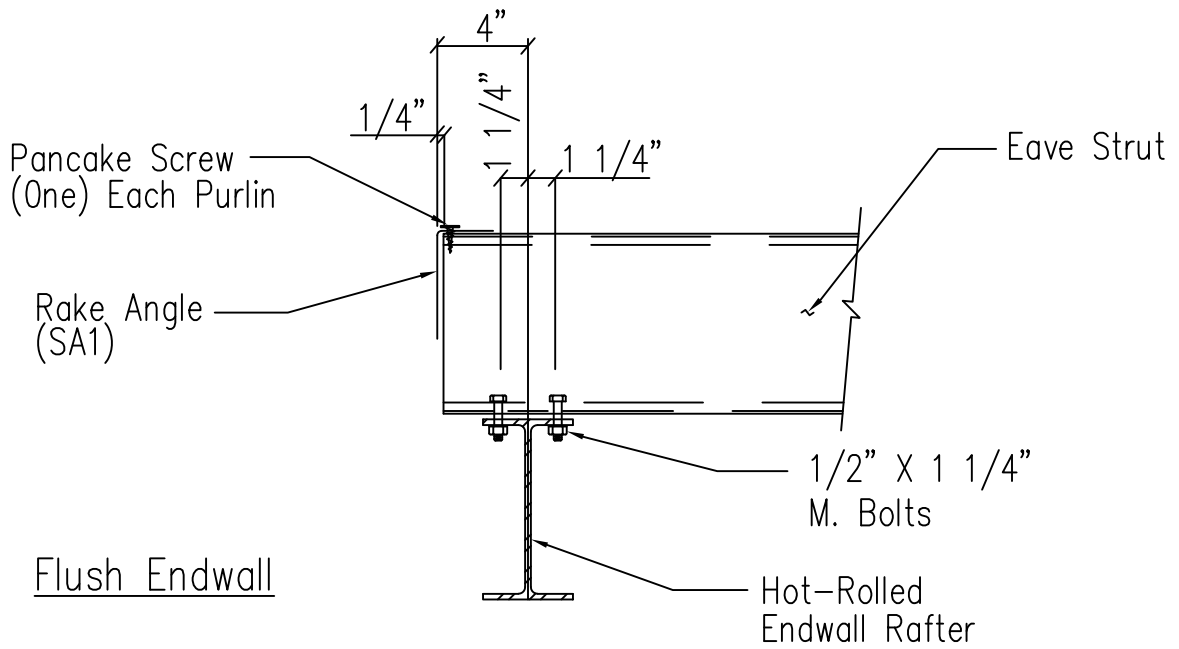

Eave Strut to Hot Rolled Rafter Connection

DRAWING NO.

SD14

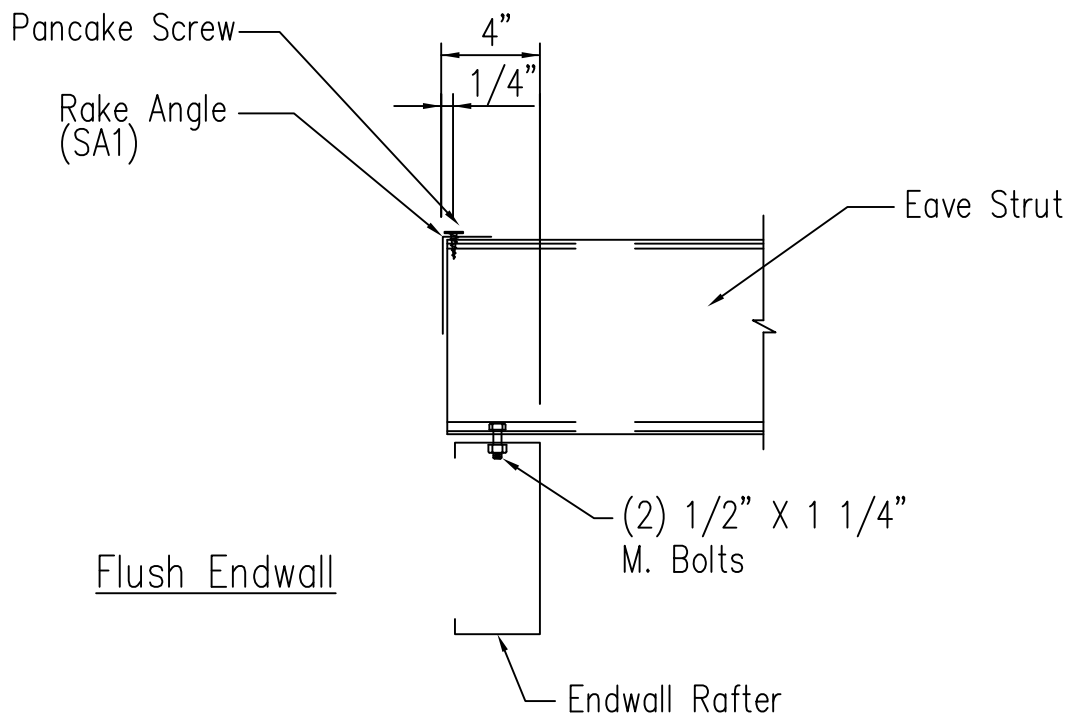
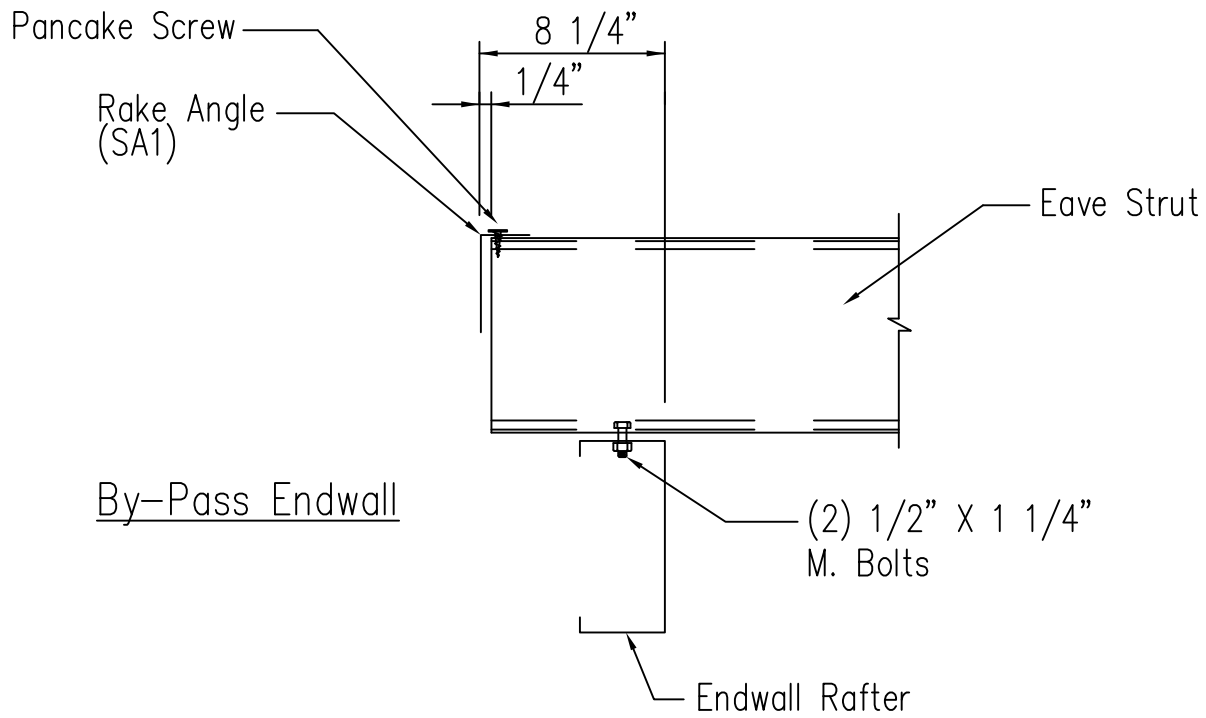

Eave Strut to Cold Form Rafter Connection

DRAWING NO.

SD15

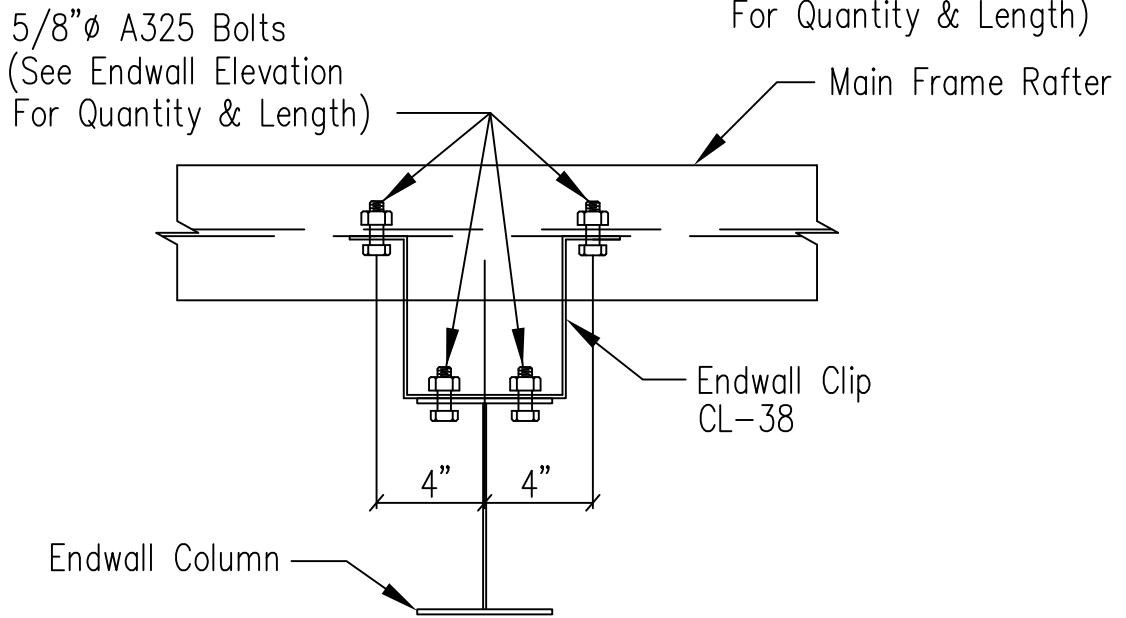
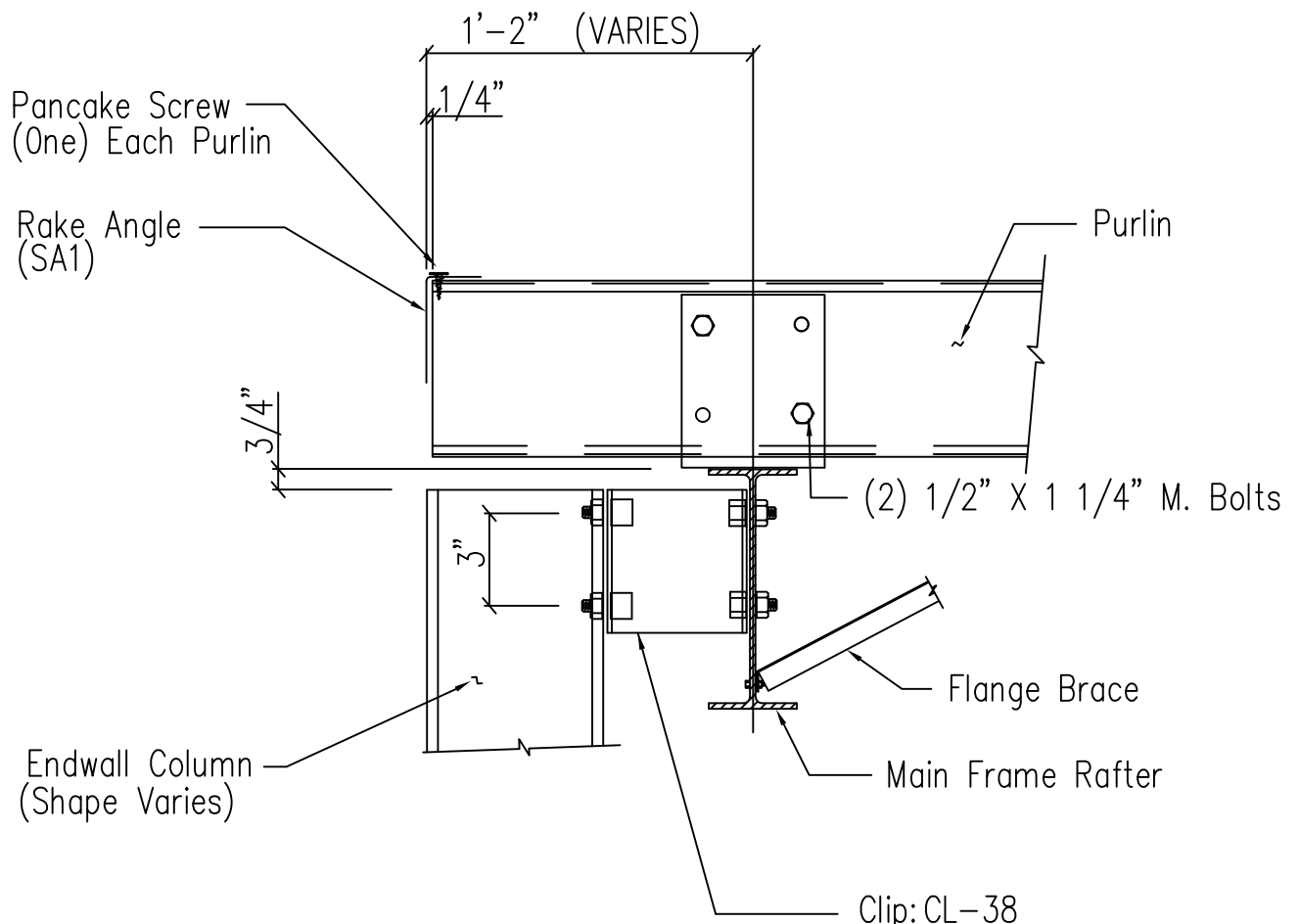

WF Column to Main Frame Rafter Connection

Flush Endwall

DRAWING NO.

SD20



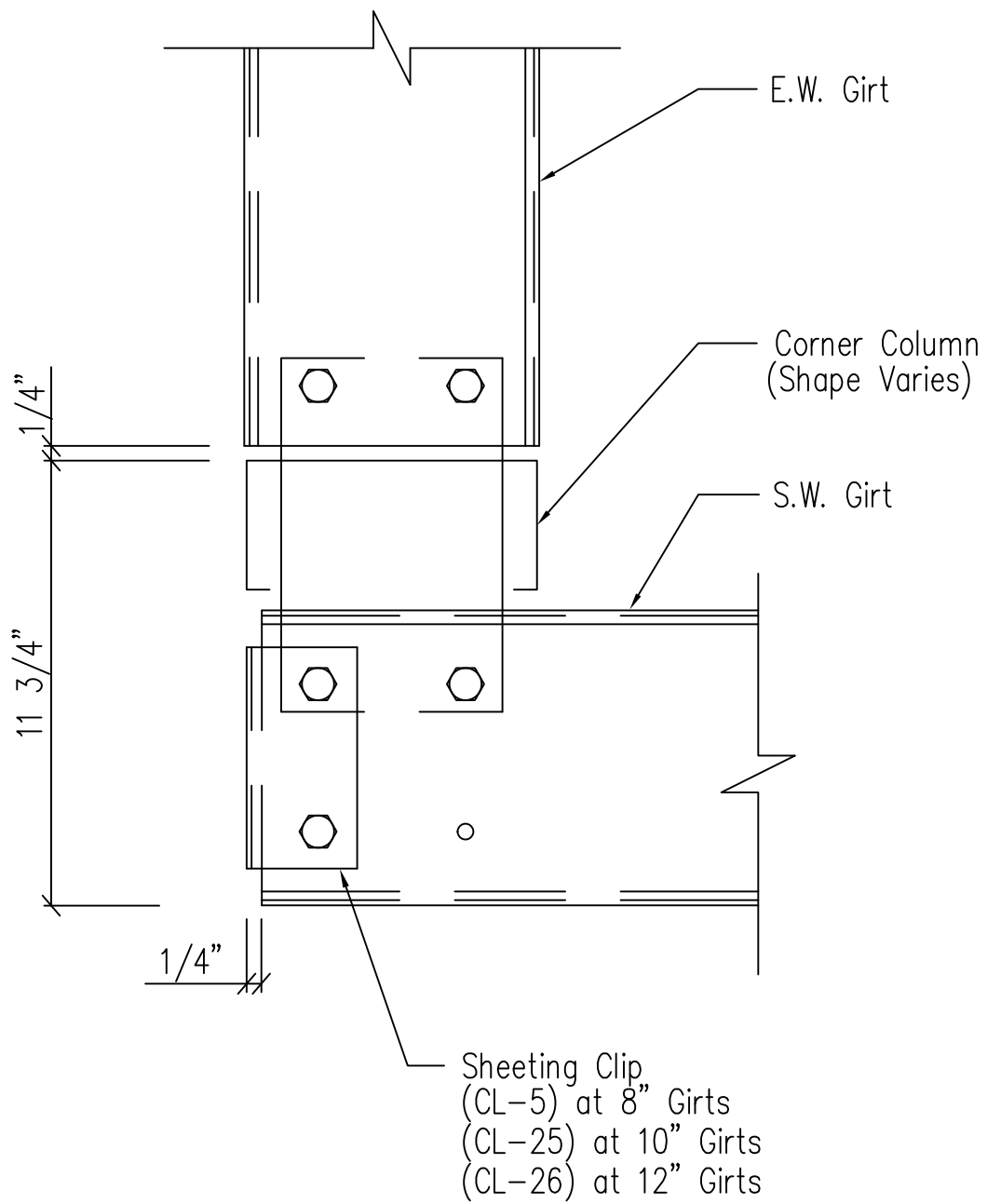

Note: All connection bolts are 1/2" x 1 1/4" machine bolts unless noted.

Section at "C" Corner Column  
Flush Endwall

DRAWING NO.

SD21

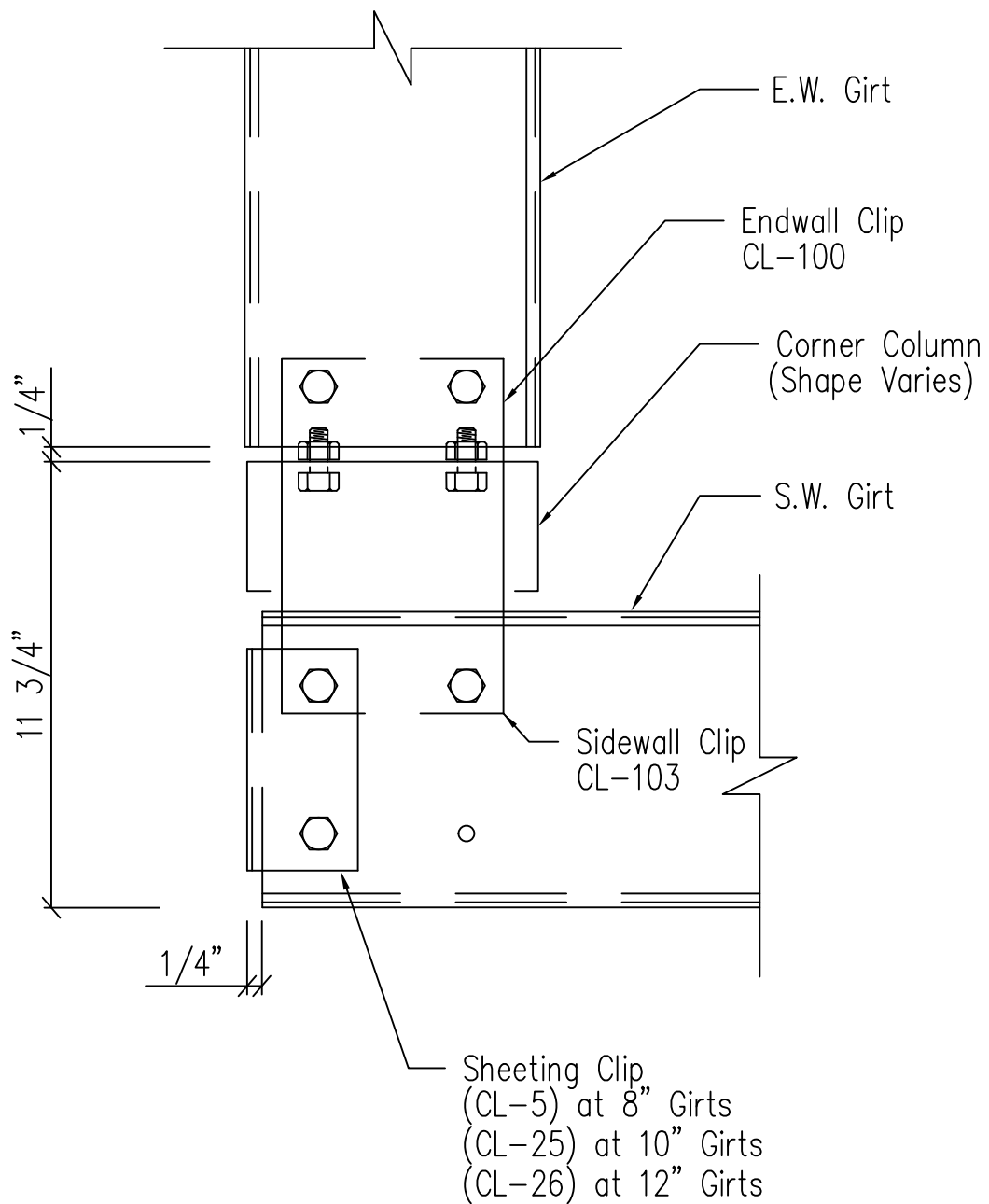

ERECTOR NOTE: IF CLIP BOXES ON BUILDING ELEVATION VIEW(S) ARE BELOW THE INTENDED GIRT LINE, THE CLIP(S) IN REFERENCE ARE TOED DOWN. IF ABOVE THE GIRT LINE, THEN TOED UP.

Note: All connection bolts are 1/2" x 1 1/4" machine bolts unless noted.

Section at "C" Corner Column  
 Flush Endwall

DRAWING NO.

SD24

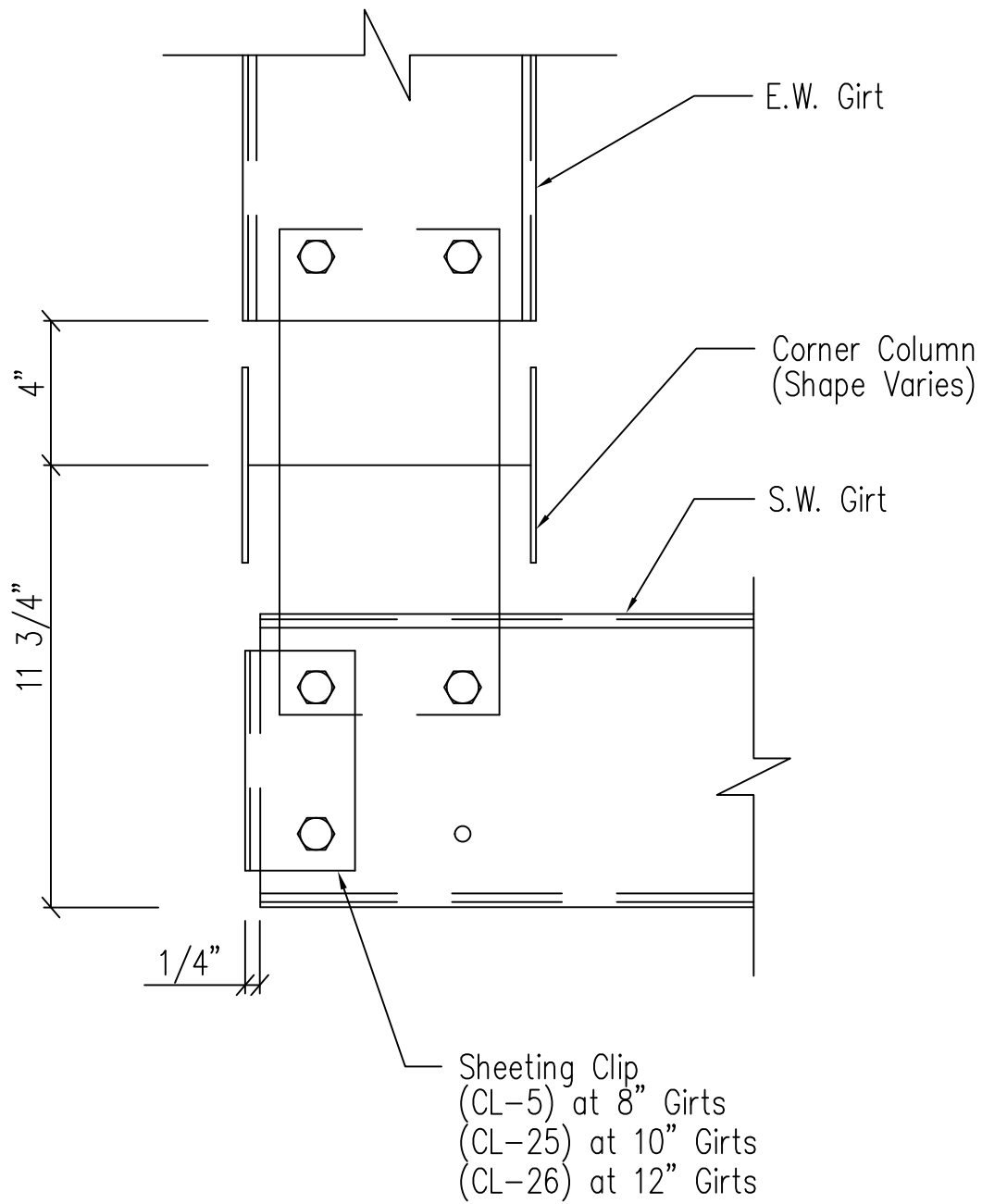

Note: All connection bolts are 1/2" x 1 1/4" machine bolts unless noted.

Section at Hot Rolled Corner Column  
Flush Endwall

DRAWING NO.  
**SD25**

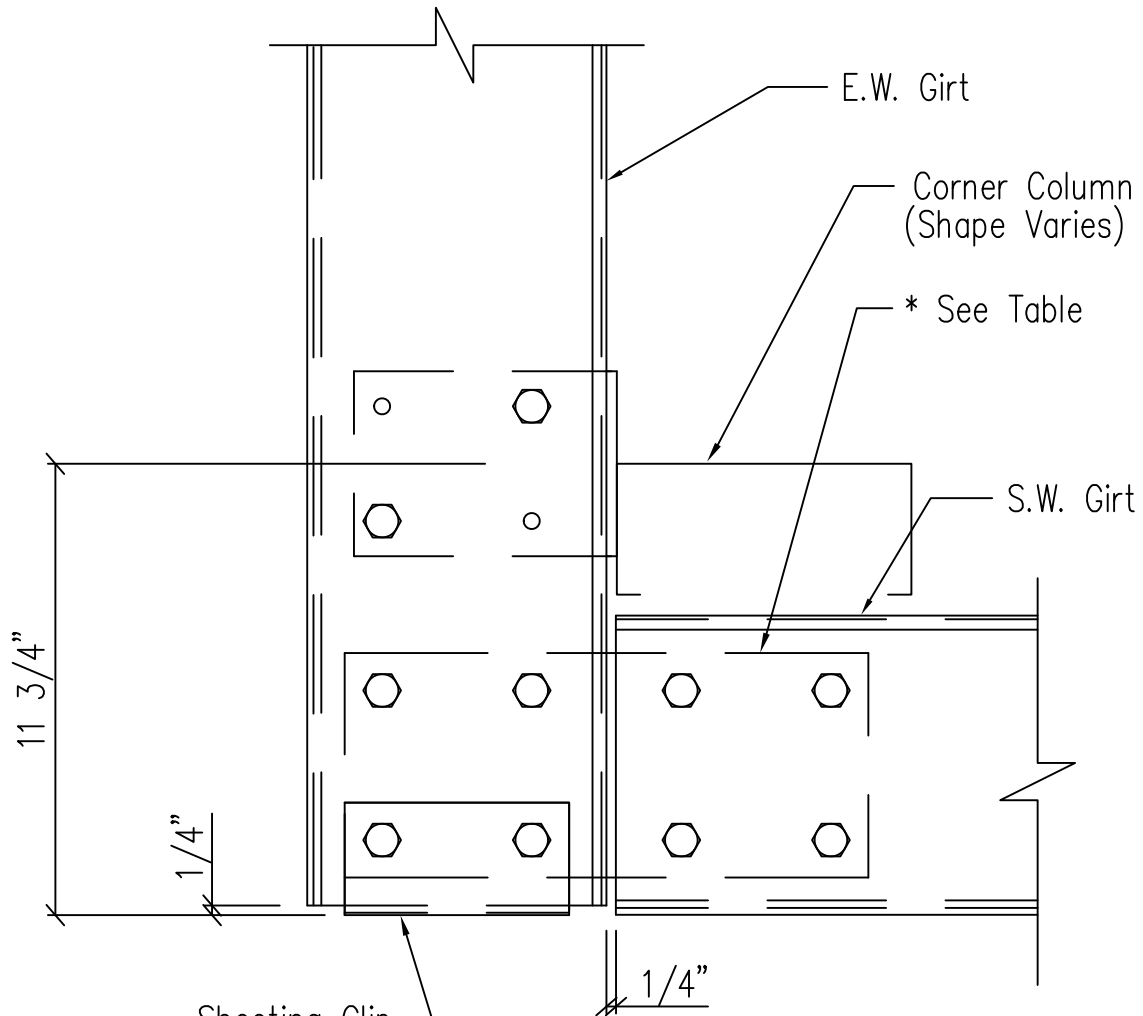

Sheeting Clip  
 (CL-5) at 8" Girts  
 (CL-25) at 10" Girts  
 (CL-26) at 12" Girts

CLIP TABLE		
EW GIRT	SW GIRT	CLIP
8"	8"	CL-64
8"	10"	CL-65
10"	8"	CL-66
10"	10"	CL-67

Note: All connection bolts are 1/2" x 1 1/4" machine bolts unless noted.

Section at "C" Corner Column  
 By-Pass Endwall

DRAWING NO.

SD26

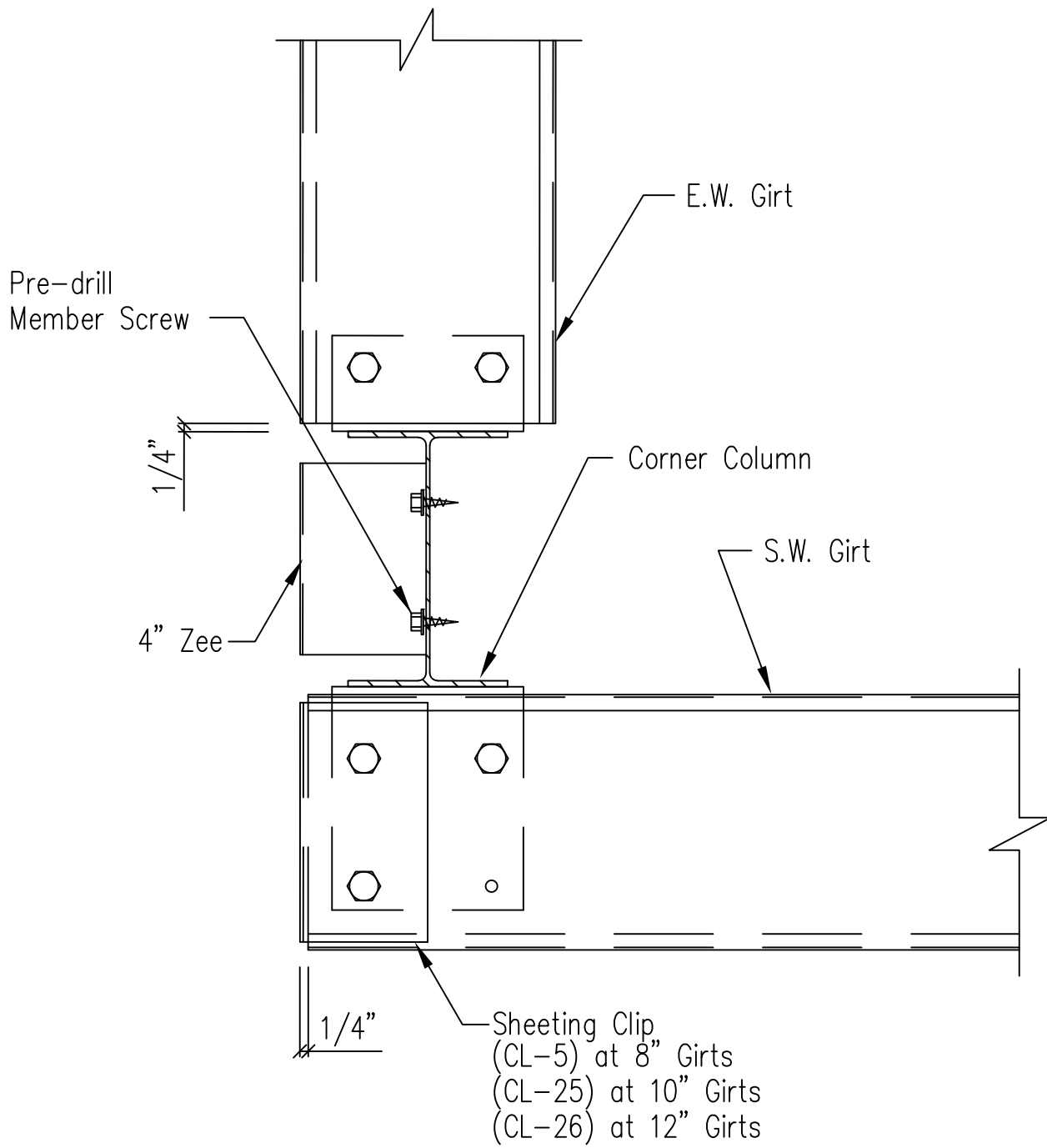

Note: All connection bolts are 1/2" x 1 1/4" machine bolts unless noted.

Section at Hot Rolled Corner Column

Flush Endwall - By-Pass Sidewall

DRAWING NO.

SD30

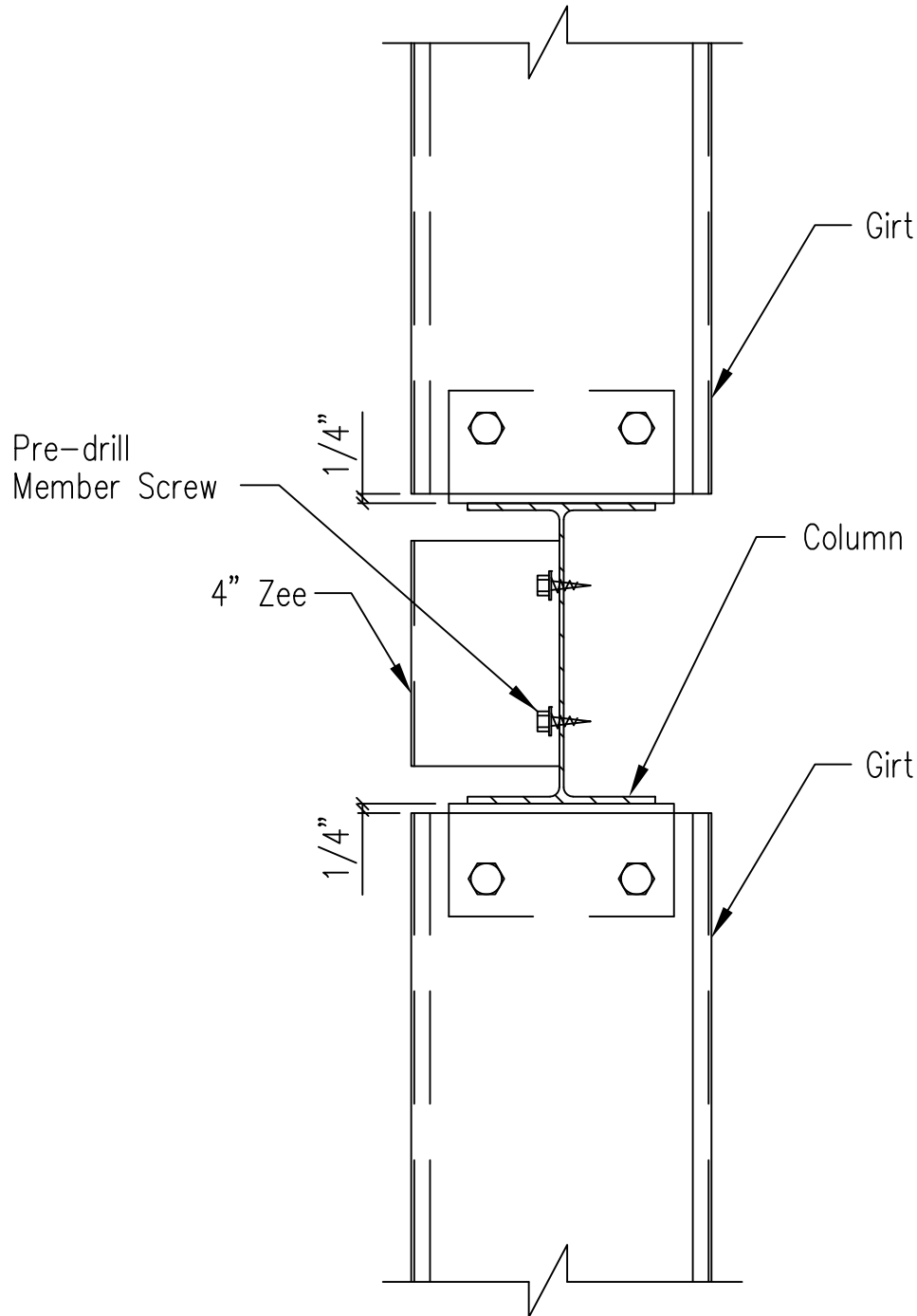

Note: All connection bolts are 1/2" x 1 1/4" machine bolts unless noted.

Section at Hot Rolled Corner Column

Flush Endwall - Open By-Pass Sidewall

DRAWING NO.

SD32

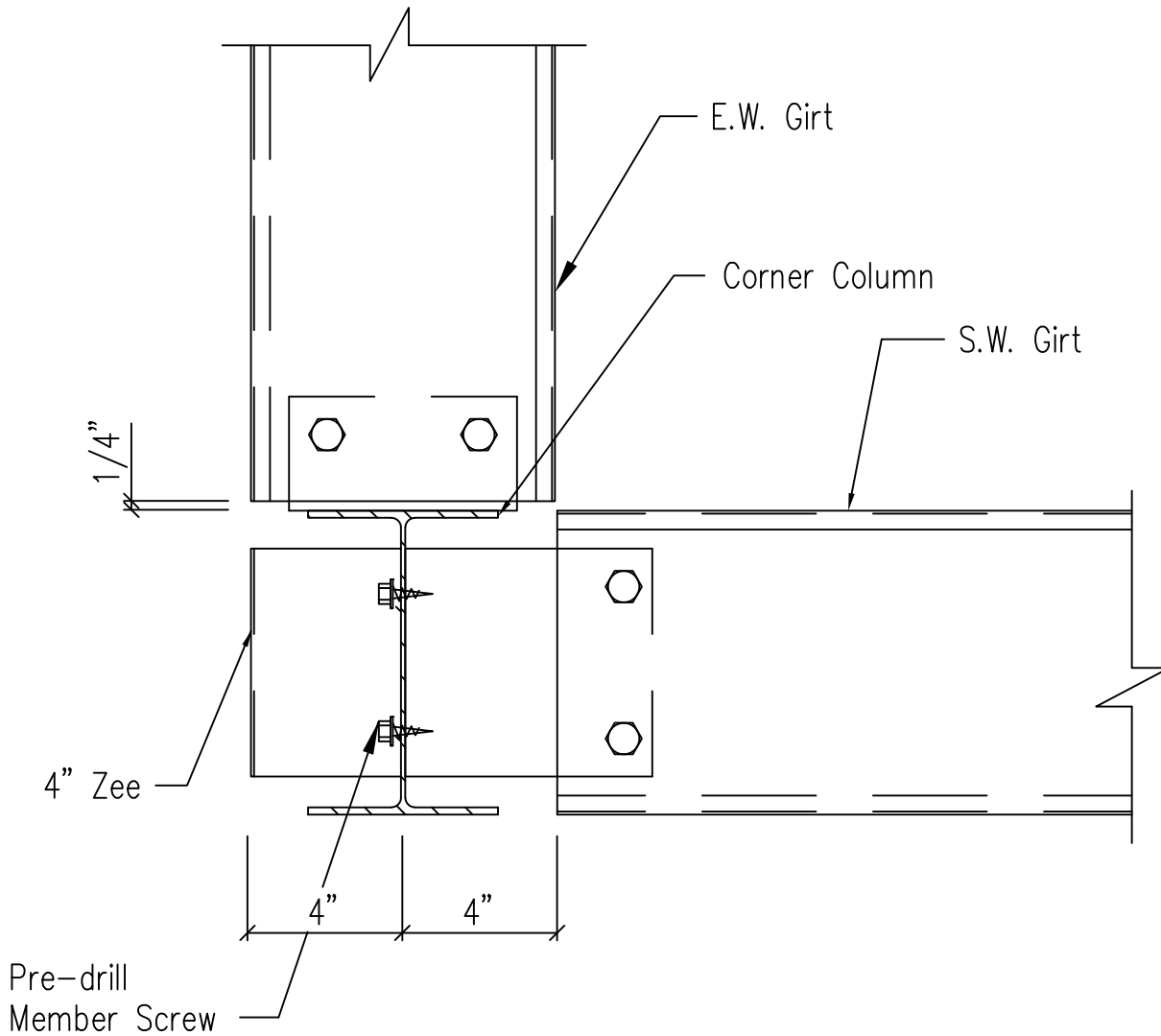

Note: All connection bolts are 1/2" x 1 1/4" machine bolts unless noted.

Section at Hot Rolled Corner Column

Flush Endwall - Flush Sidewall

DRAWING NO.

SD33

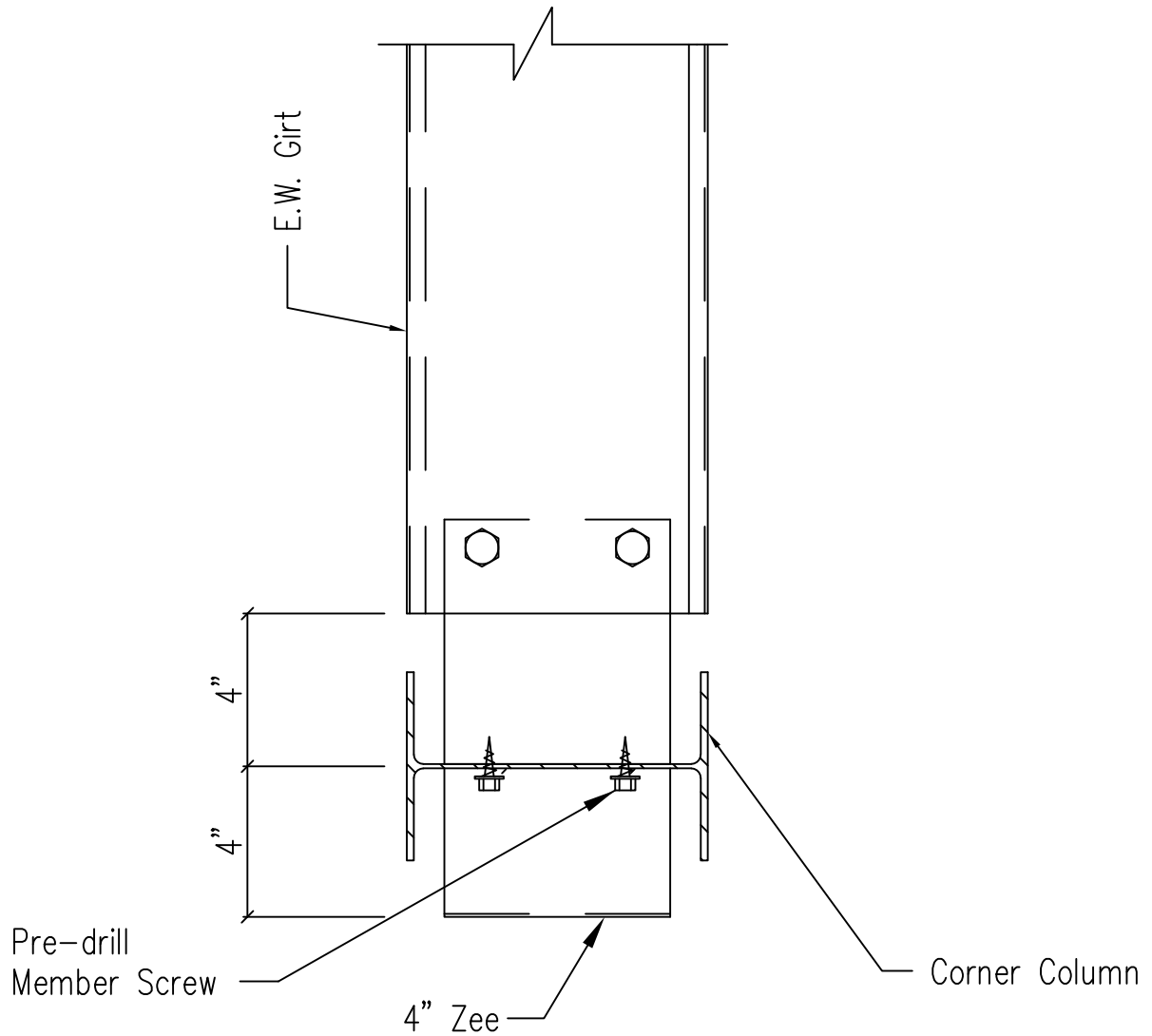

Note: All connection bolts are 1/2" x 1 1/4" machine bolts unless noted.

## Section at Hot Rolled Corner Column

Flush Endwall - Flush Sidewall - Open Sidewall

DRAWING NO.

SD34



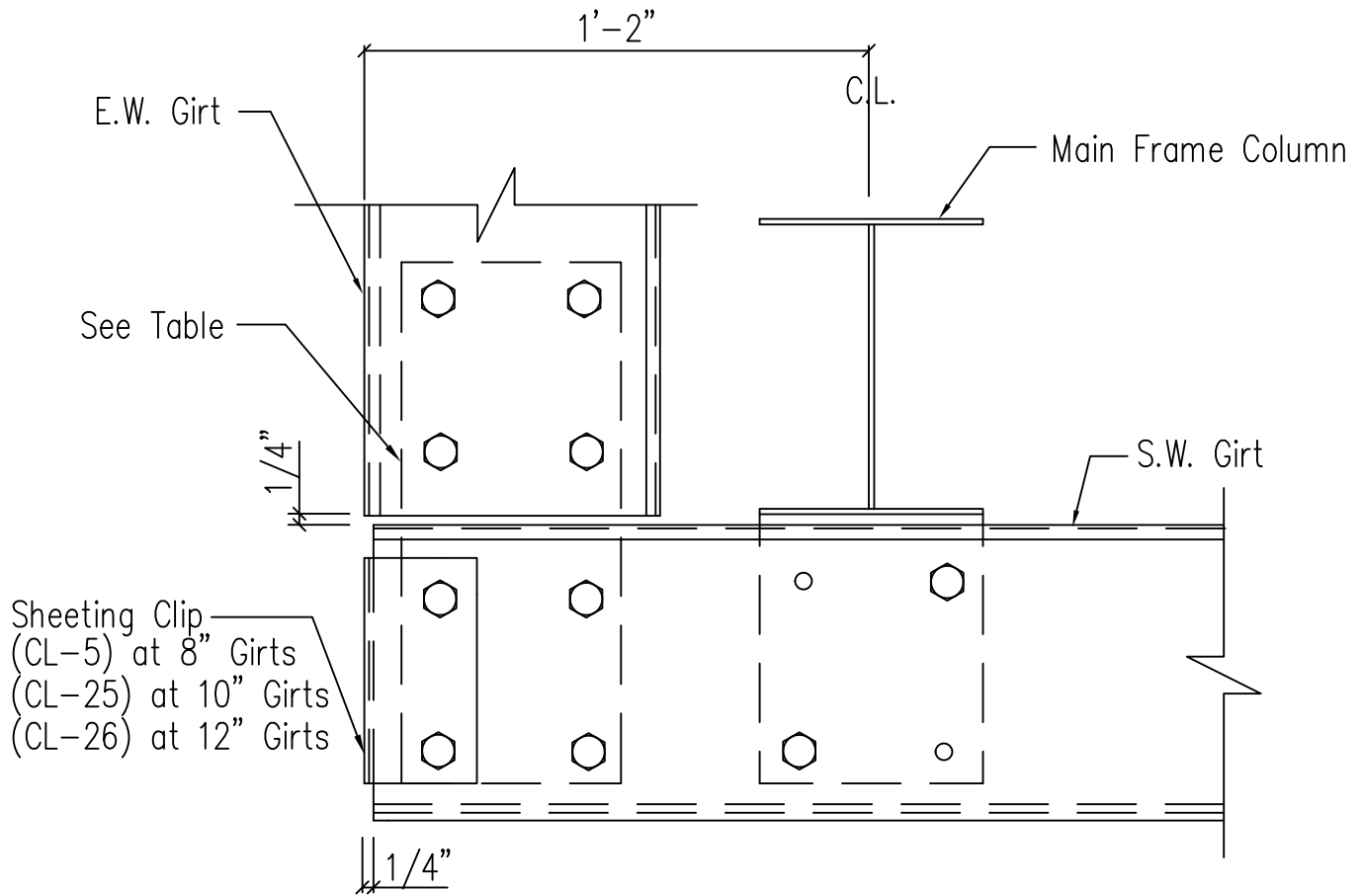

Sheeting Clip  
 (CL-5) at 8" Girts  
 (CL-25) at 10" Girts  
 (CL-26) at 12" Girts

CLIP TABLE		
SW GIRT	EW. GIRT	CLIP
8"	8"	CL-64
8"	10"	CL-65
10"	8"	CL-66
10"	10"	CL-67

Note: All connection bolts are 1/2" x 1 1/4" machine bolts unless noted.

Section at MF Corner Column  
 Flush Endwall

DRAWING NO.

SD36

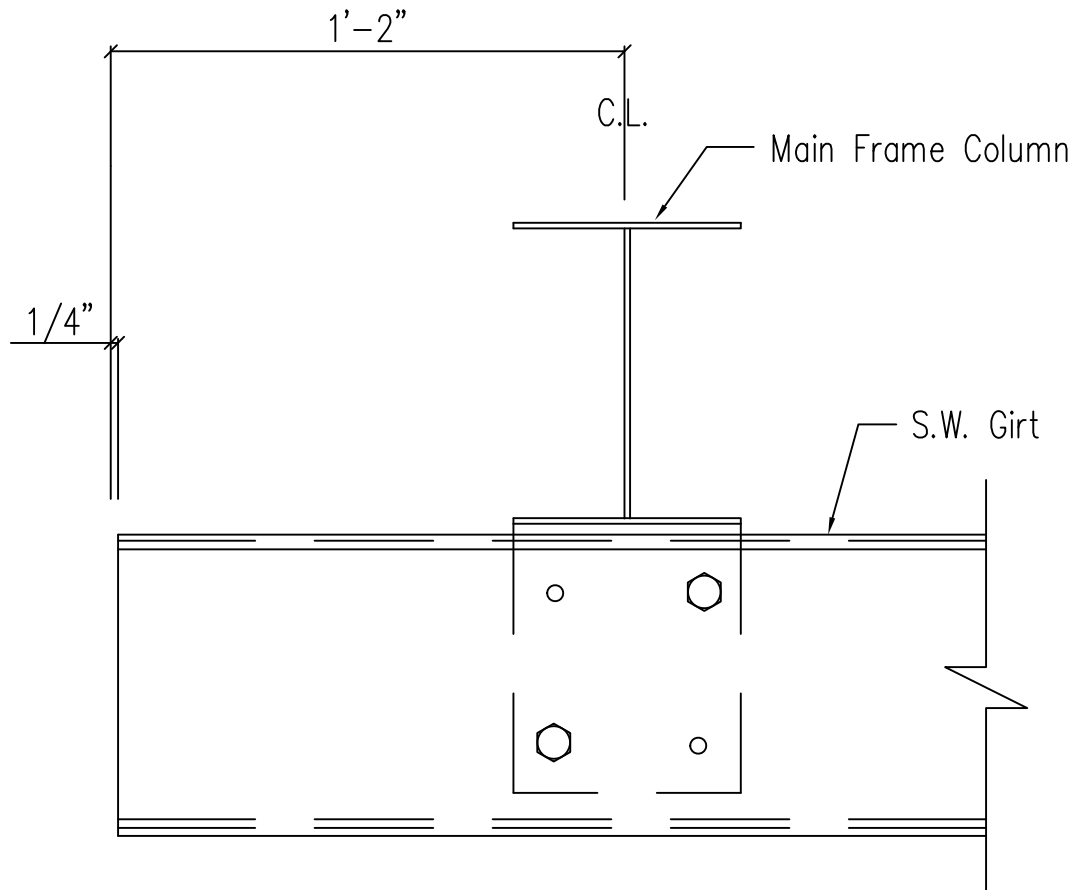

Note: All connection bolts are 1/2" x 1 1/4" machine bolts unless noted.

Section at Rigid Frame Corner Column

Flush Endwall - Open By-Pass Sidewall

DRAWING NO.

SD37

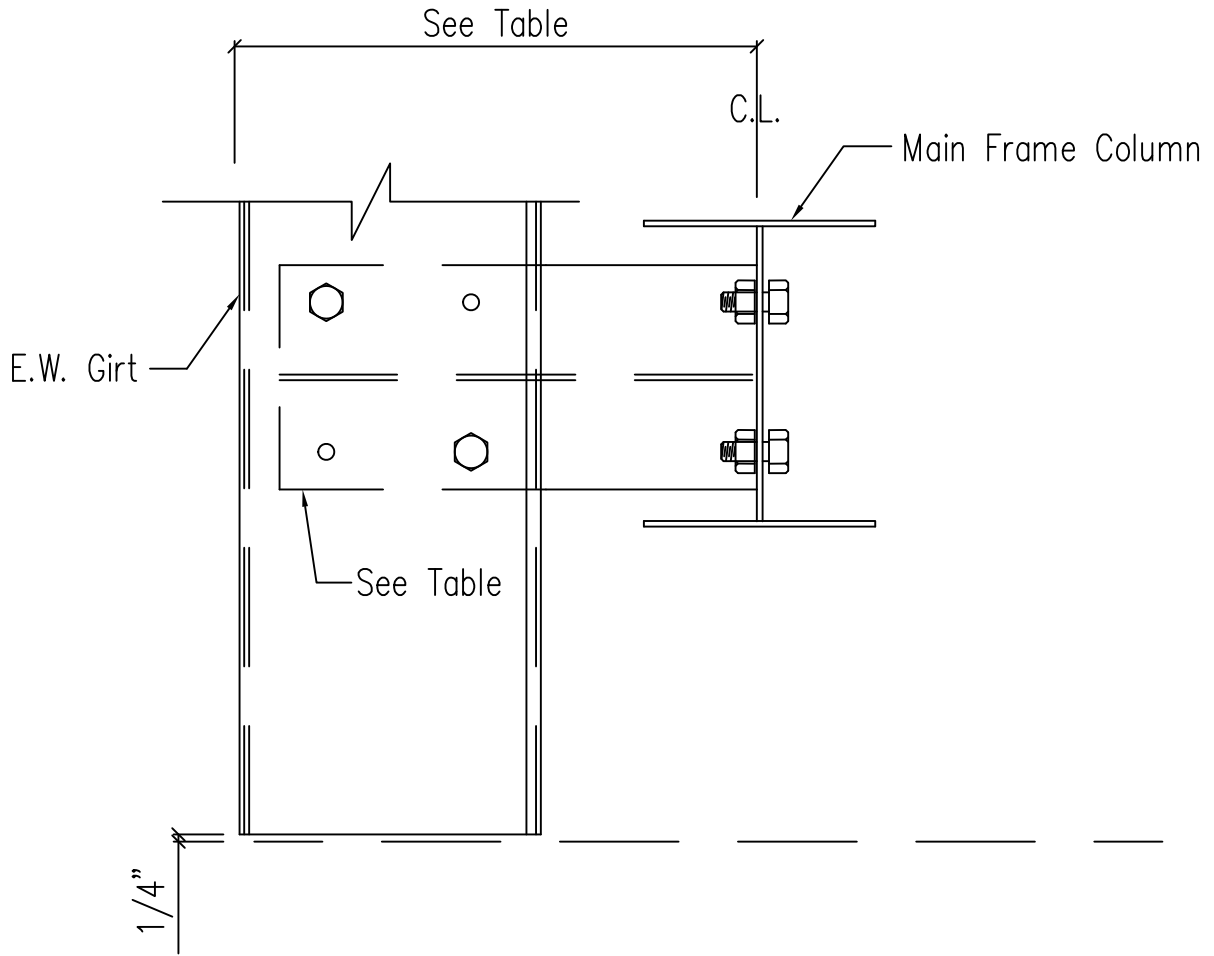

GIRT DEPTH	CLIP	DIMENSION
8"	CL-61	1'-2"
10"	CL-62	1'-2"
1'-0"	CL-61	1'-4"

Note: All connection bolts are 1/2" x 1 1/4" machine bolts unless noted.

## Section at MF Corner Column

Flush Endwall - Open By-Pass Sidewall

DRAWING NO.

SD38

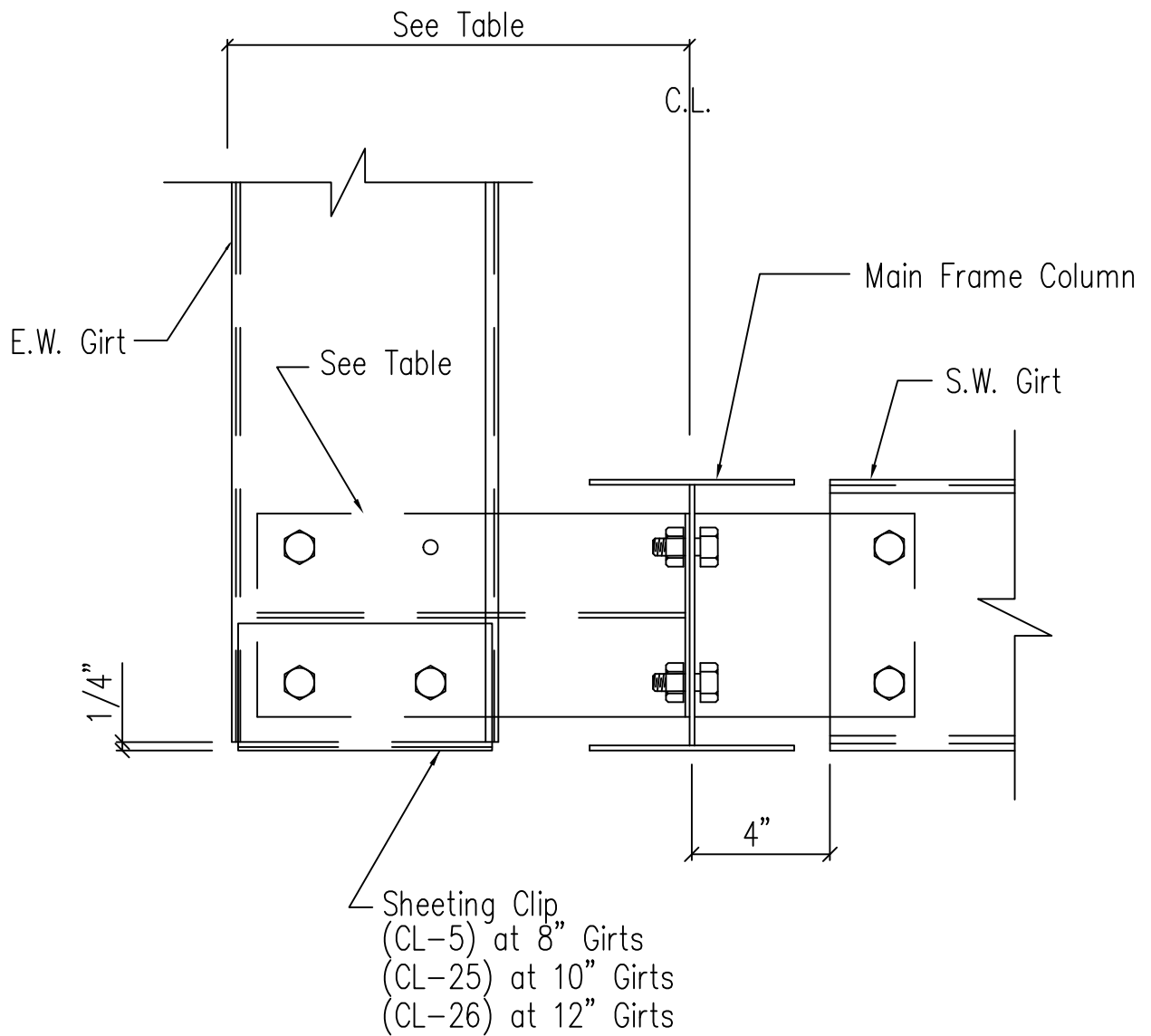

GIRT DEPTH	CLIP	DIMENSION
8"	CL-61	1'-2"
10"	CL-62	1'-2"
1'-0"	CL-61	1'-4"

Note: All connection bolts are 1/2" x 1 1/4" machine bolts unless noted.

## Section at MF Corner Column

By-Pass Endwall - Flush Sidewall

DRAWING NO.

SD39

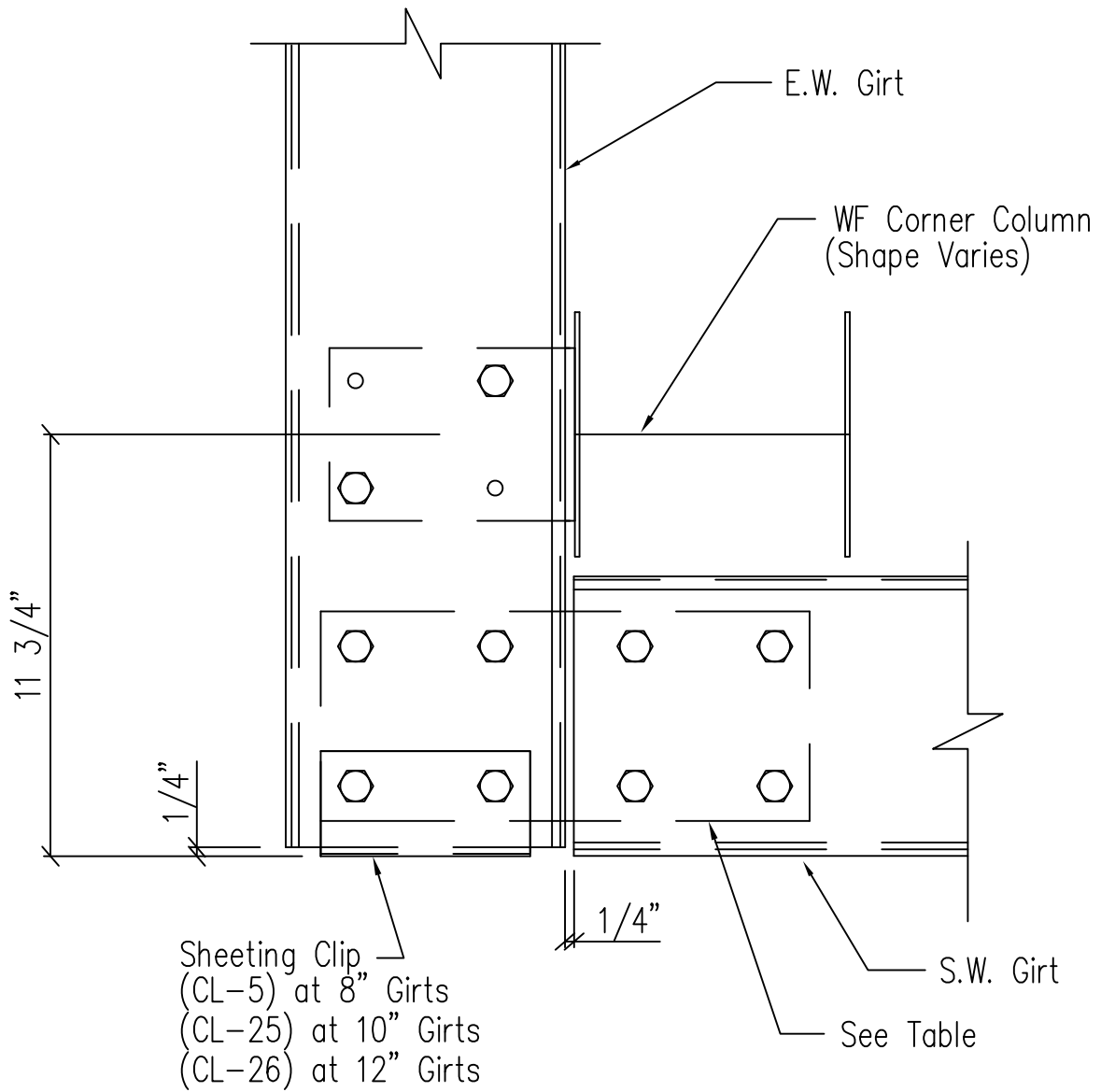

CLIP TABLE		
EW GIRT	SW GIRT	CLIP
8"	8"	CL-64
8"	10"	CL-65
10"	8"	CL-66
10"	10"	CL-67

Note: All connection bolts are 1/2" x 1 1/4" machine bolts unless noted.

## Section at W.F. Corner Column

By-Pass Endwall

DRAWING NO.

SD42

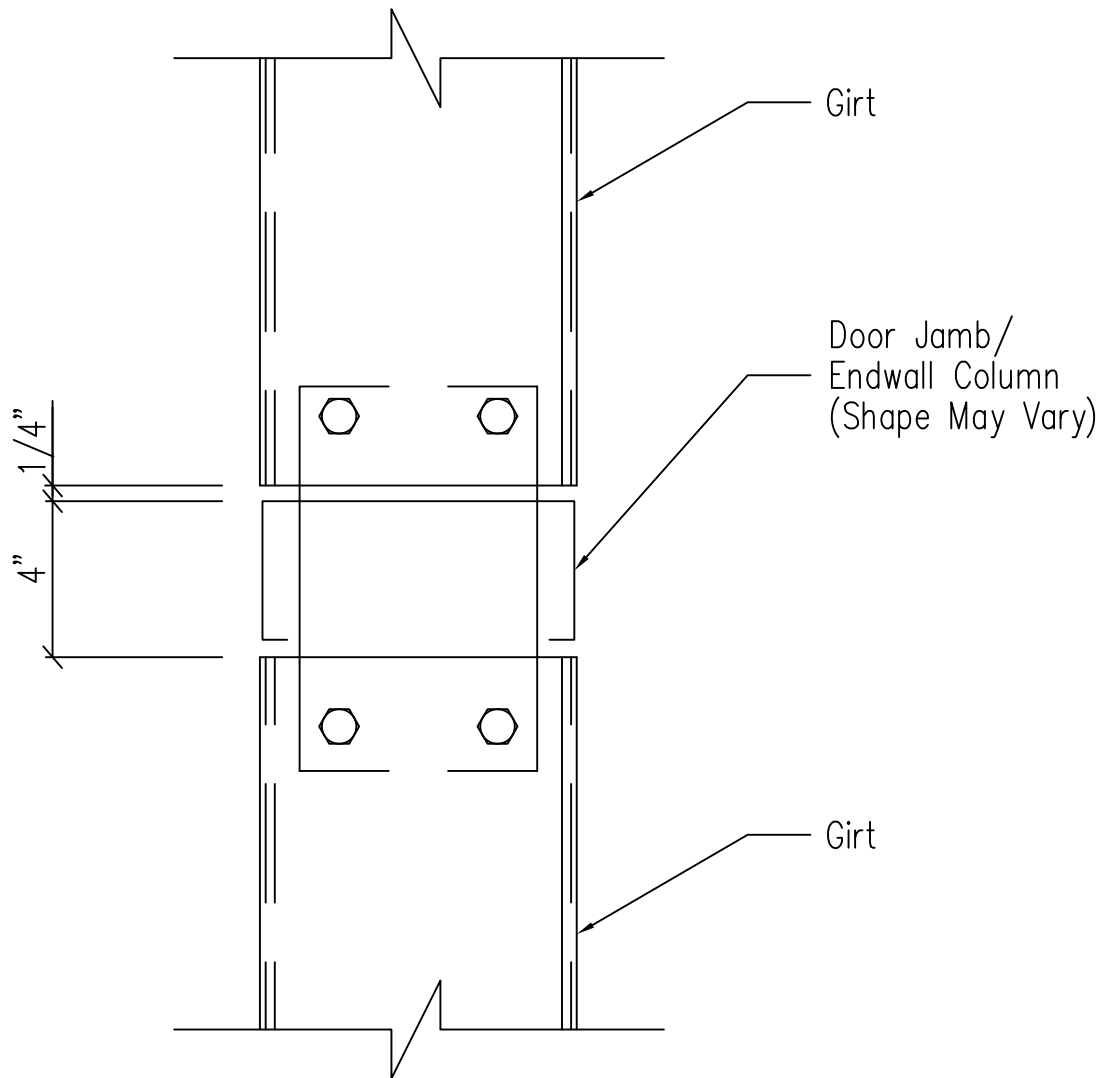

Note: All connection bolts are 1/2" x 1 1/4" machine bolts unless noted.

Girt to "C" Door Jamb/Endwall Column Connection

DRAWING NO.

SD43

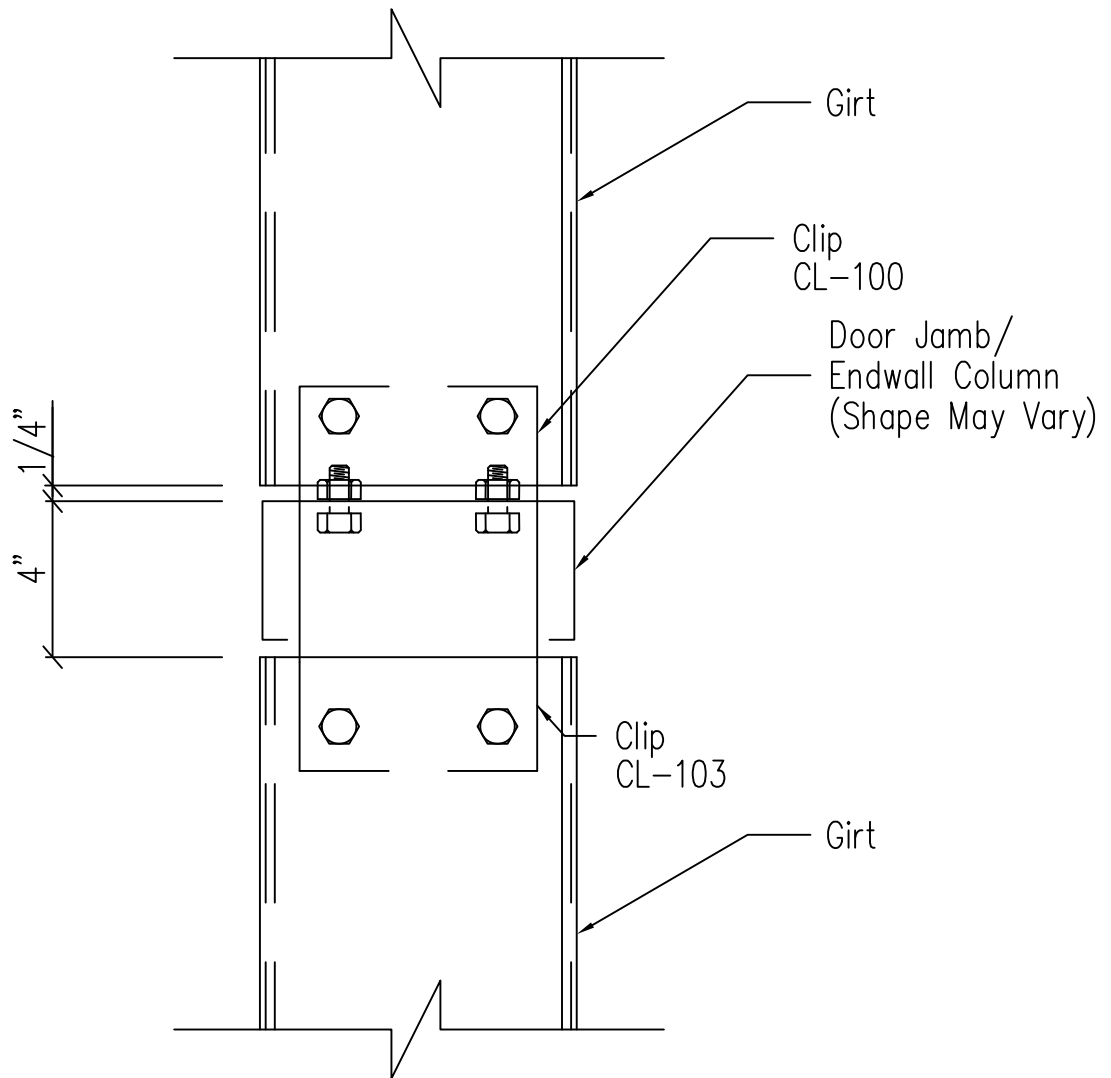

ERECTOR NOTE: IF CLIP BOXES ON BUILDING ELEVATION VIEW(S) ARE BELOW THE INTENDED GIRT LINE, THE CLIP(S) IN REFERENCE ARE TOED DOWN. IF ABOVE THE GIRT LINE, THEN TOED UP.

Note: All connection bolts are 1/2" x 1 1/4" machine bolts unless noted.

Girt to "C" Door Jamb/Endwall Column Connection

DRAWING NO.  
**SD43**

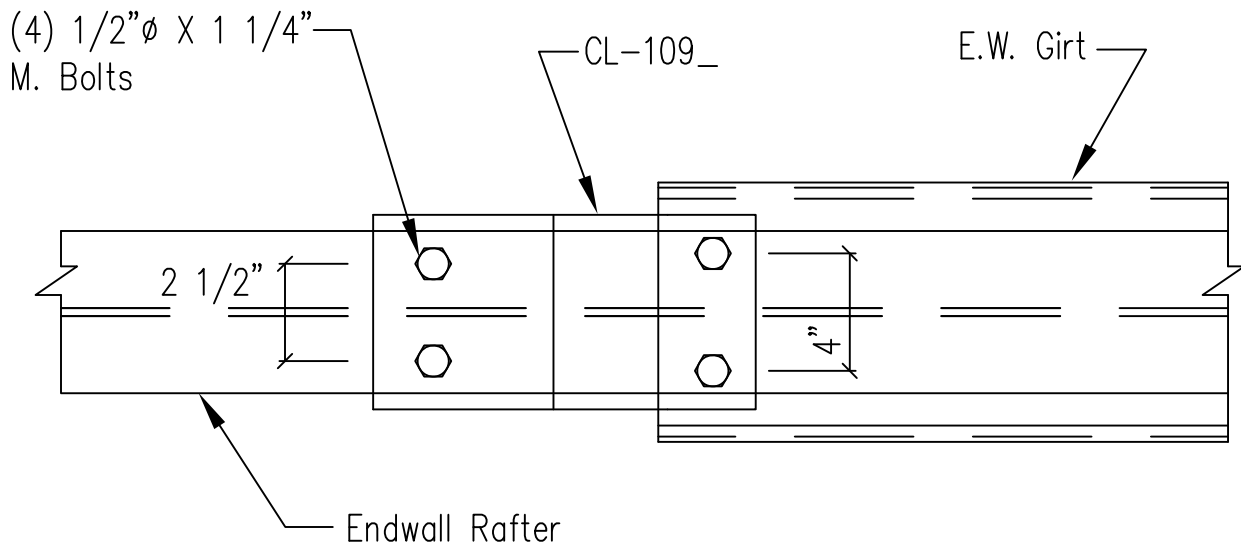
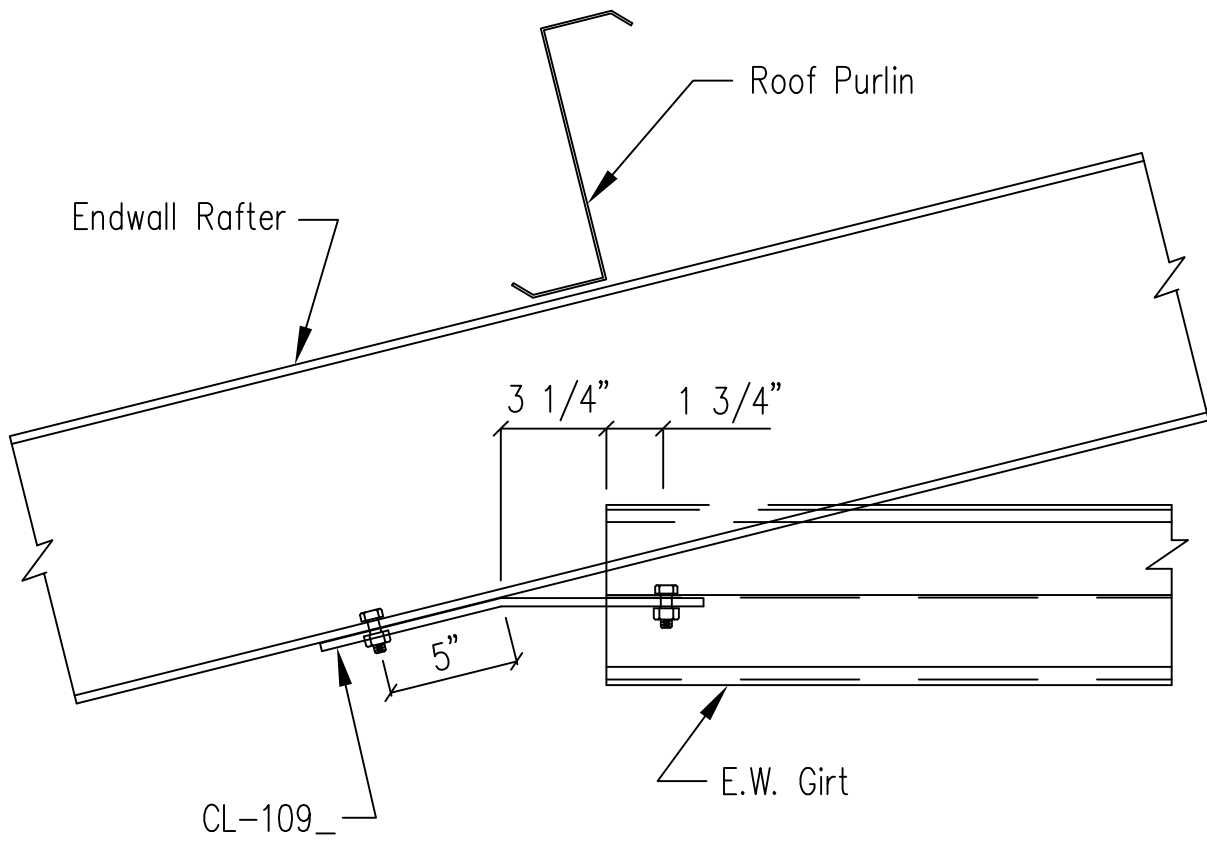

Endwall Girt to Hot Rolled Rafter

DRAWING NO.

SD45



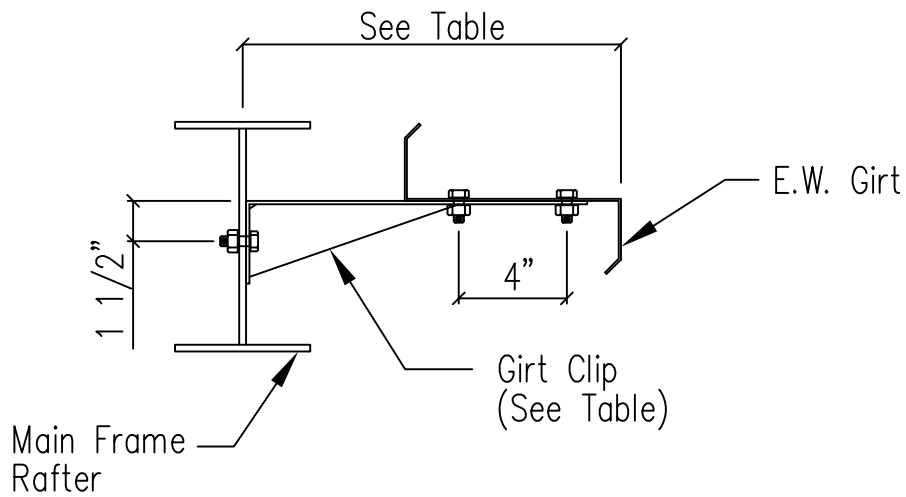
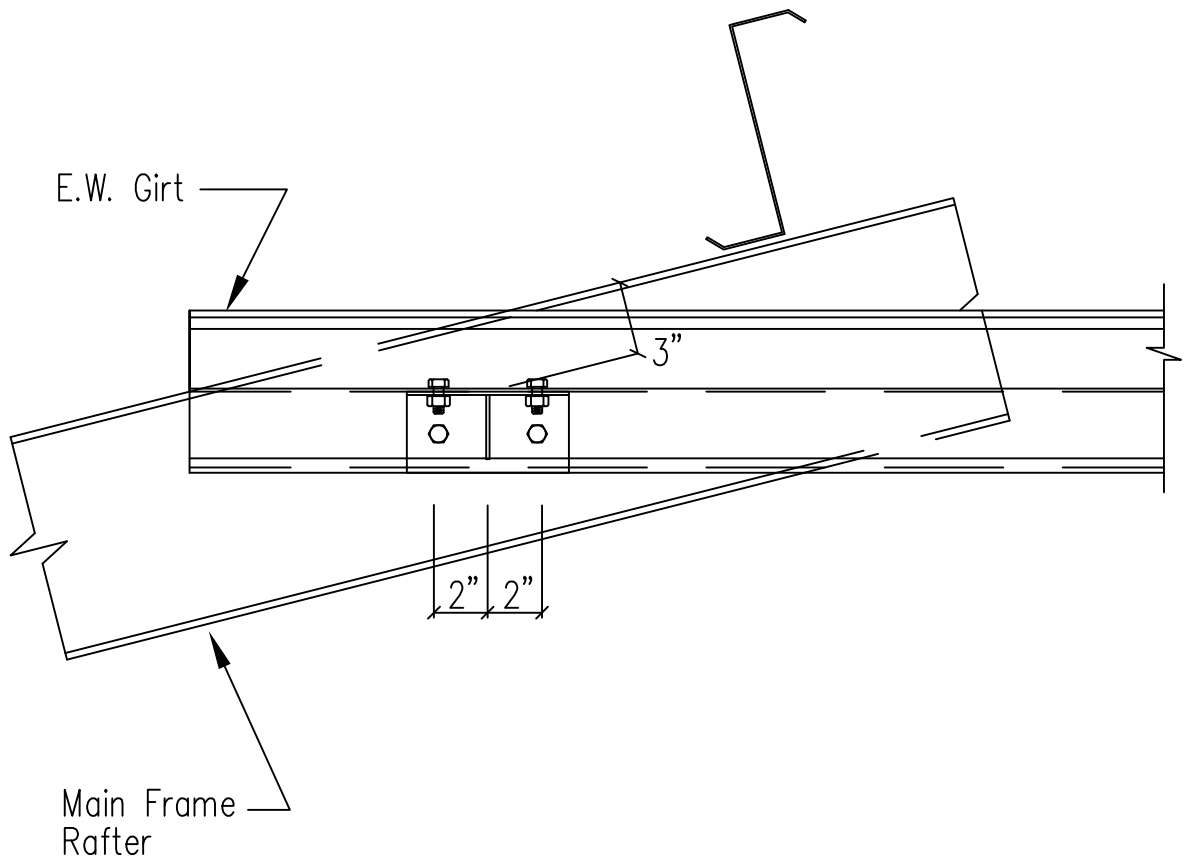

GIRT DEPTH	CLIP	DIMENSION
8"	CL-107	1'-2"
10"	CL-108	1'-2"
1'-0"	CL-107	1'-4"

All Bolts are 1/2" x 1 1/4" A307 Bolt

Endwall Girt to M.F. Rafter

DRAWING NO.

SD46

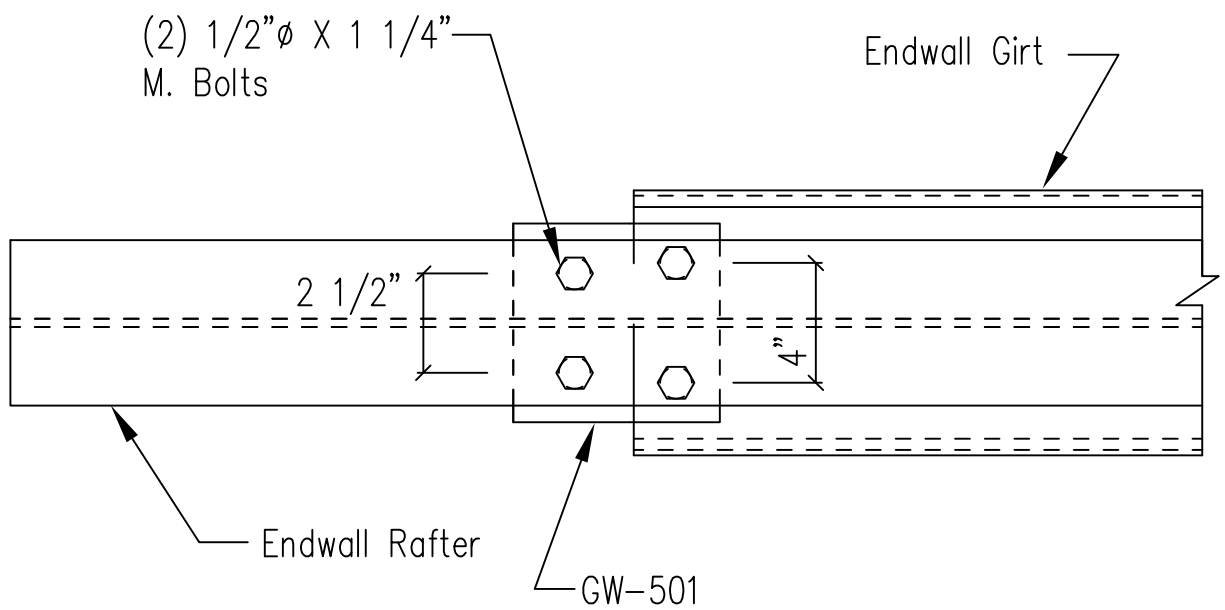
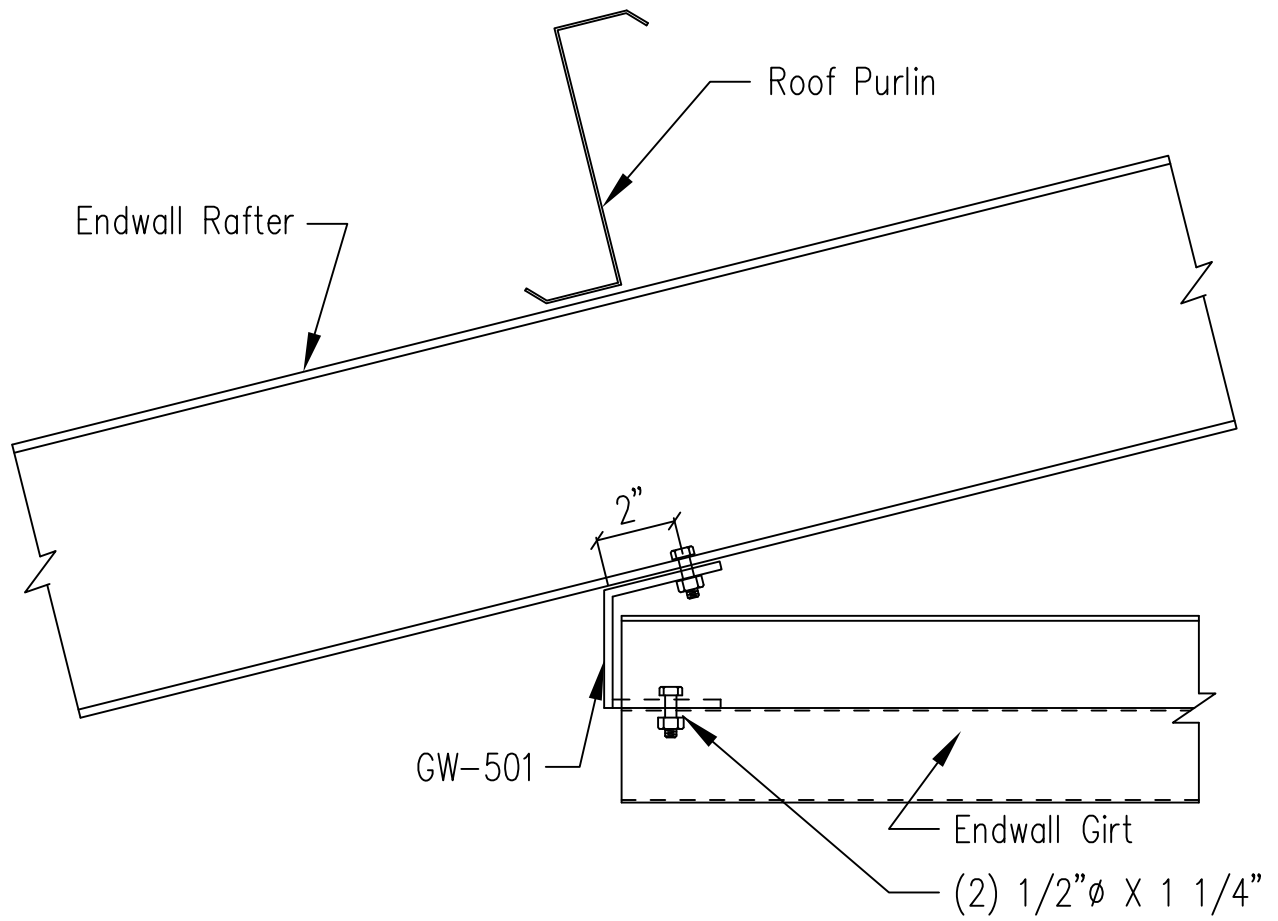

Girt to Rafter

DRAWING NO.

SD46

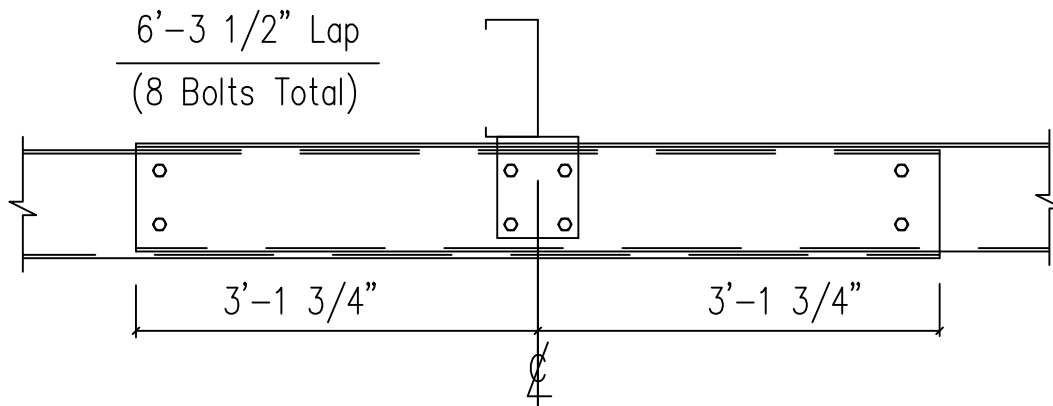
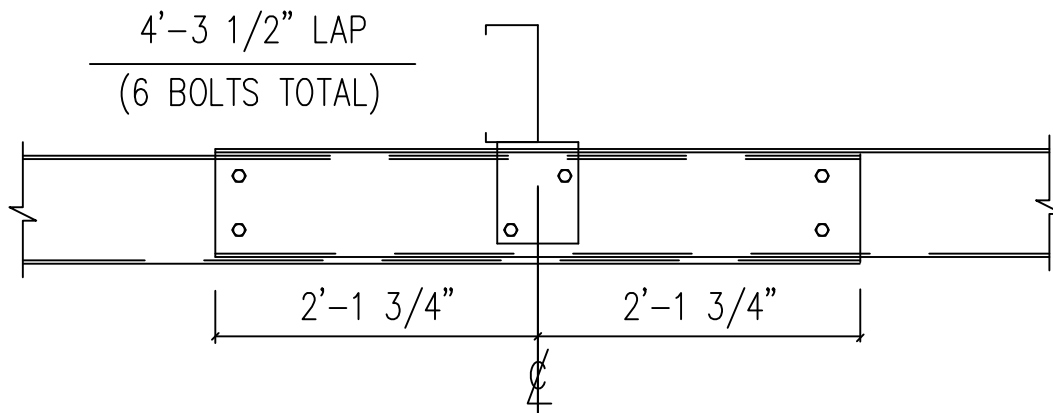
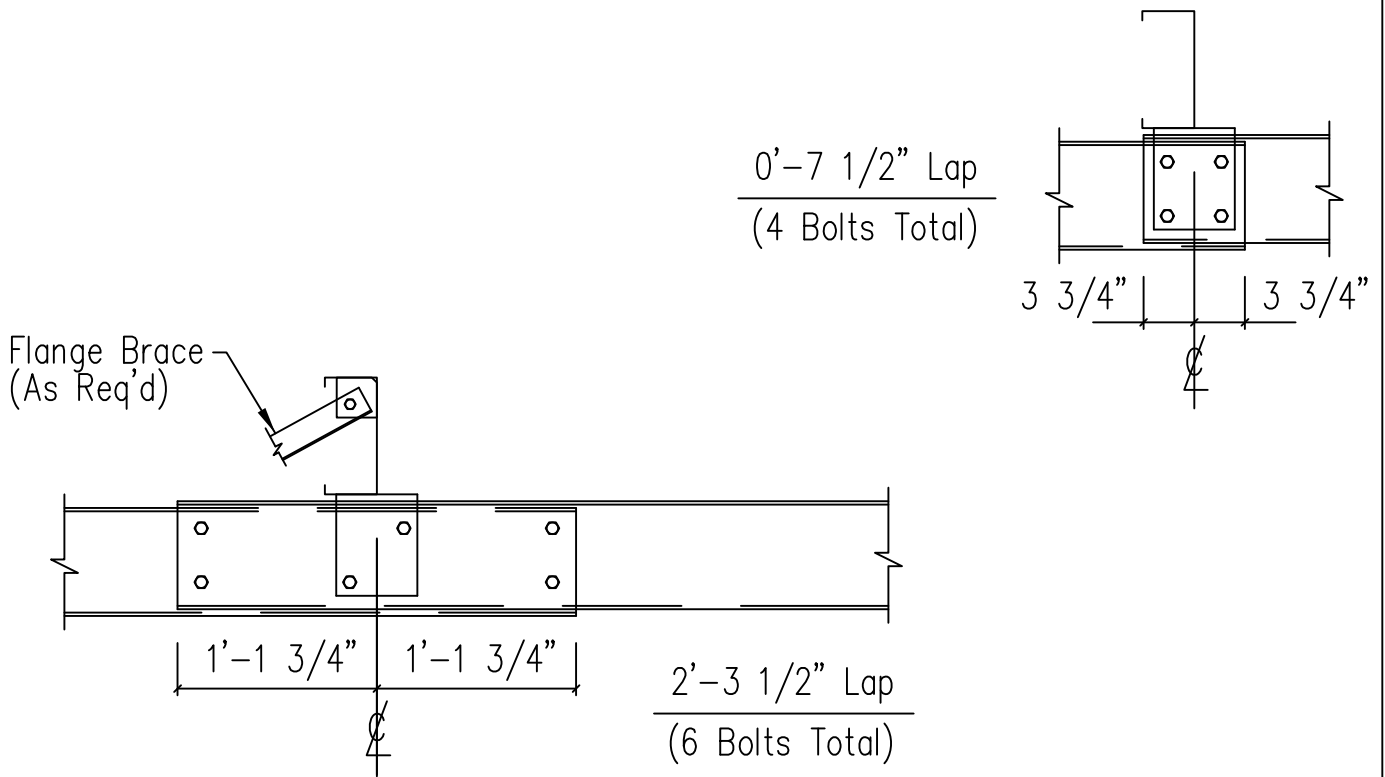

Note: All connection bolts are 1/2" x 1 1/4" machine bolts unless noted.

"C" Endwall Column to By-Pass Girt

DRAWING NO.

SD53