

Note: All connection bolts are 1/2" x 1 1/4" machine bolts unless noted.

Girt to "C" Door Jamb/Endwall Column Connection

DRAWING NO.

SD43

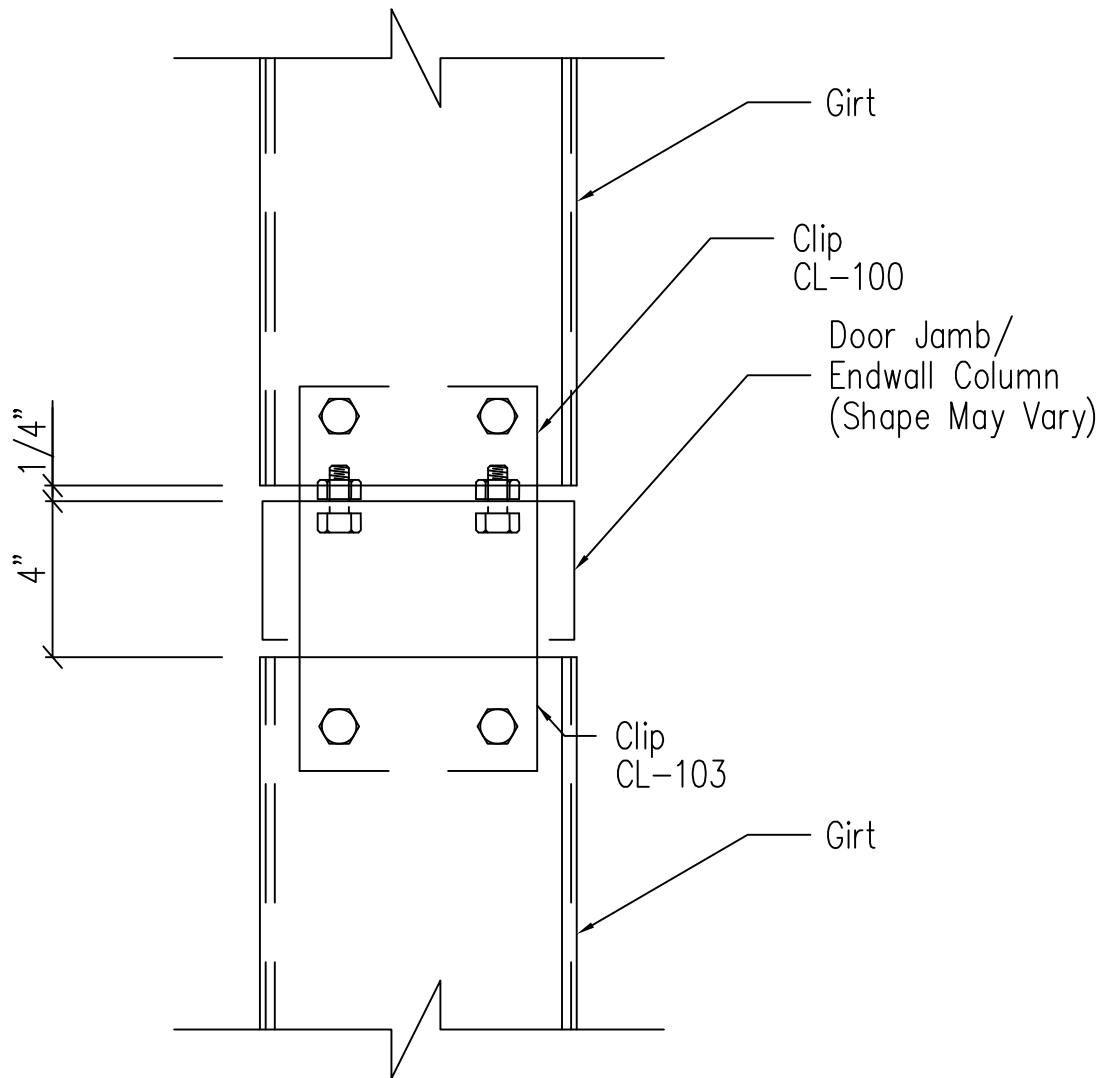

ERECTOR NOTE: IF CLIP BOXES ON BUILDING ELEVATION VIEW(S) ARE BELOW THE INTENDED GIRT LINE, THE CLIP(S) IN REFERENCE ARE TOED DOWN. IF ABOVE THE GIRT LINE, THEN TOED UP.

Note: All connection bolts are 1/2" x 1 1/4" machine bolts unless noted.

Girt to "C" Door Jamb/Endwall Column Connection

DRAWING NO.  
**SD43**

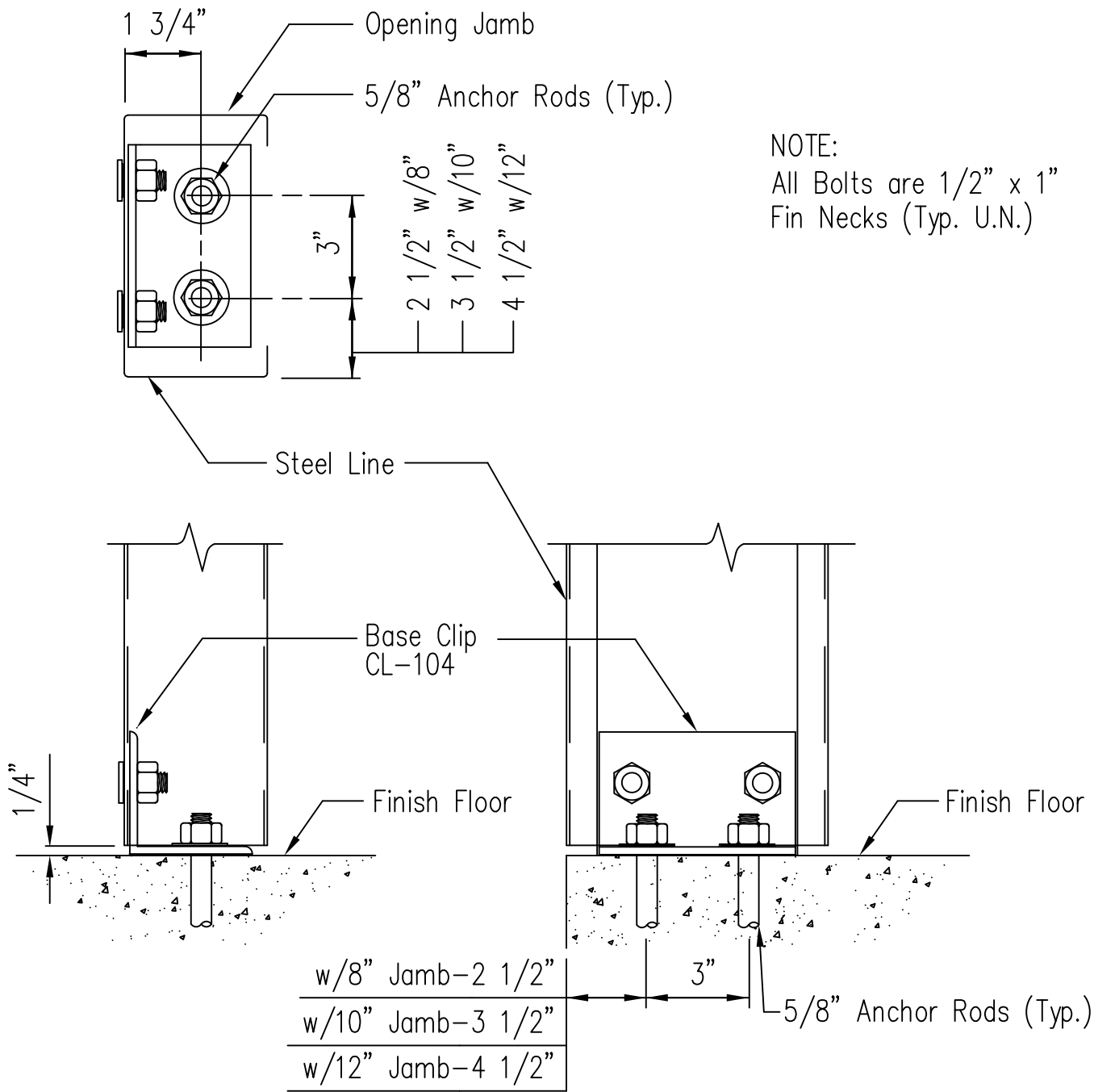

NOTE:  
 All Bolts are 1/2" x 1"  
 Fin Necks (Typ. U.N.)

Jamb to Floor

DRAWING NO.  
 SD85

NOTE:

All Bolts are 1/2" x 1 1/4"

A307 M. Bolts

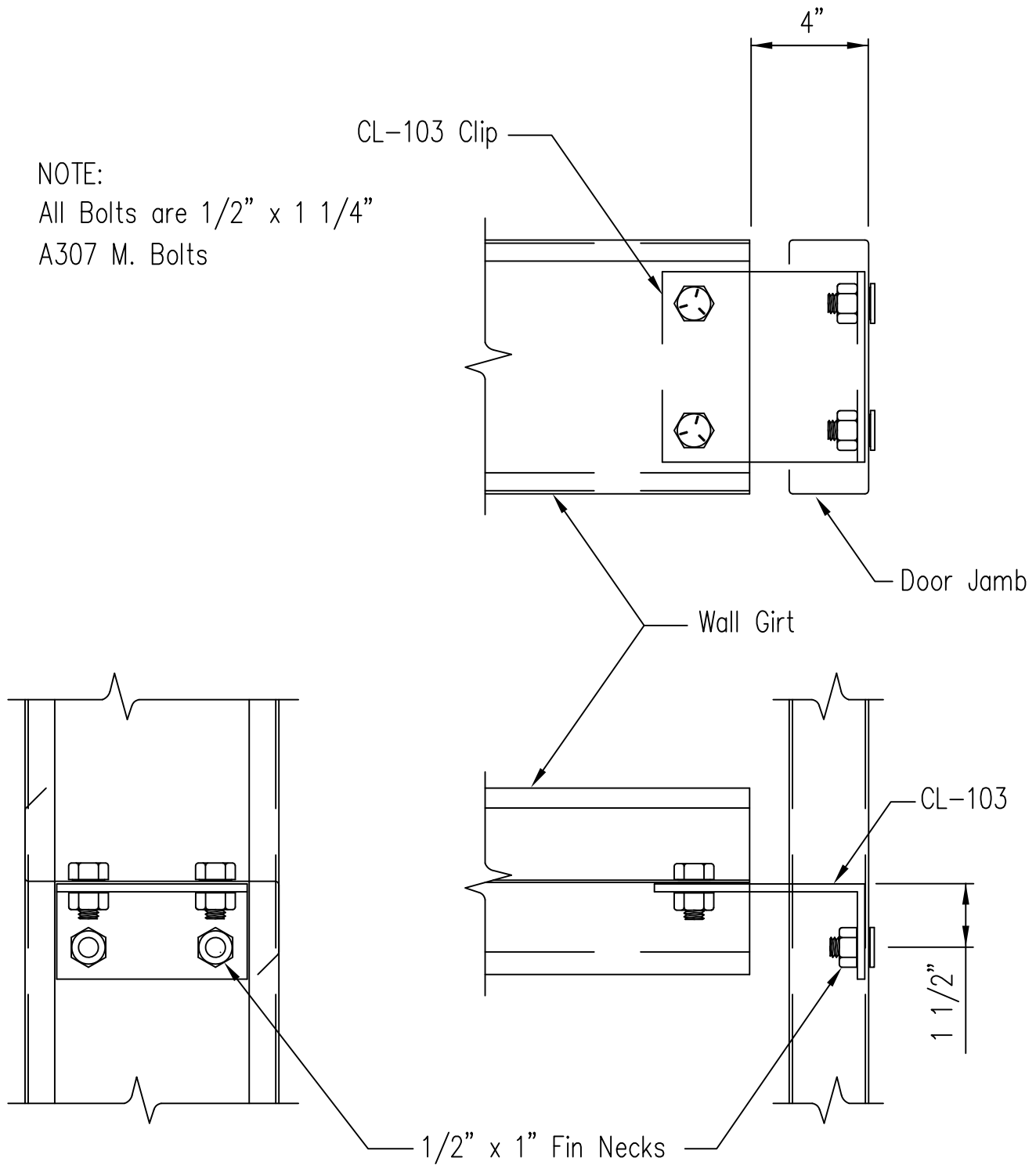

ERECTOR NOTE: IF CLIP BOXES ON BUILDING ELEVATION VIEW(S) ARE BELOW THE INTENDED GIRT LINE, THE CLIP(S) IN REFERENCE ARE TOED DOWN. IF ABOVE THE GIRT LINE, THEN TOED UP. THE DRAWINGS ABOVE ARE TOED DOWN FOR REFERENCE.

Girt to Jamb (Bolted Clips)

DRAWING NO.

SD87

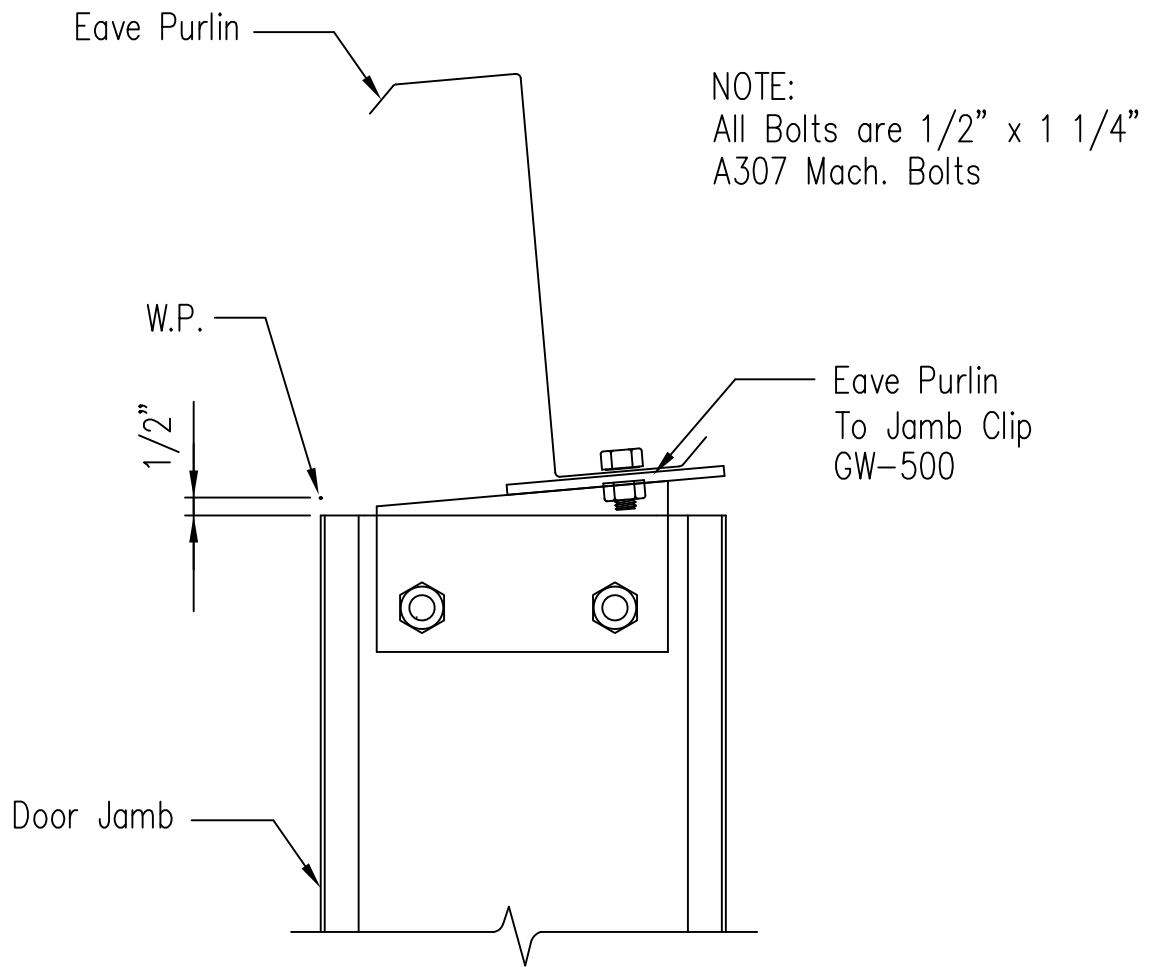

Jamb To Eave Strut  
7:12 Roof Pitch and Higher

DRAWING NO.

SD89

NOTE:  
All Bolts are 1/2" x 1 1/4"  
A307 Mach. Bolts

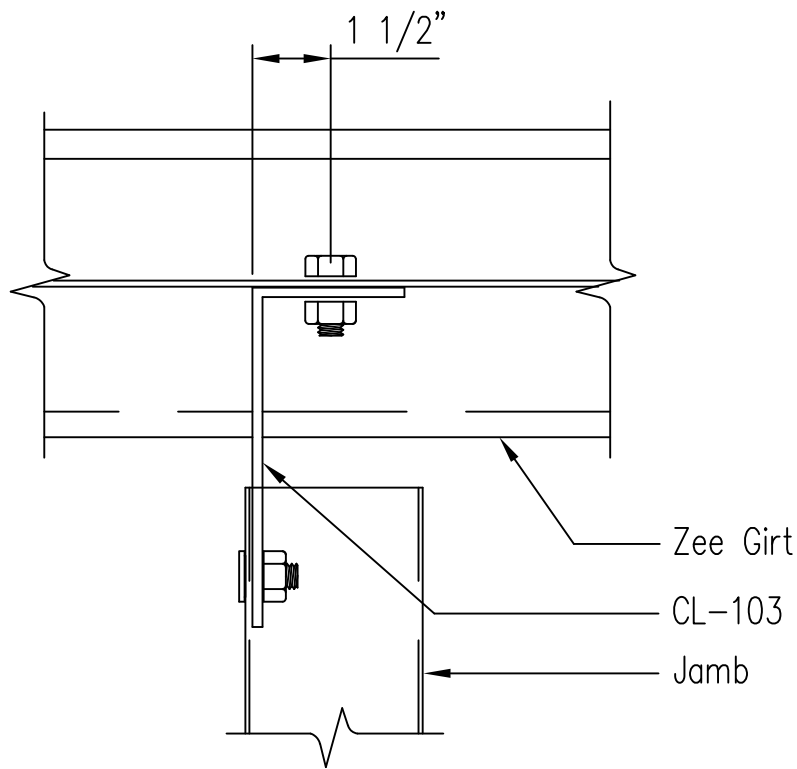
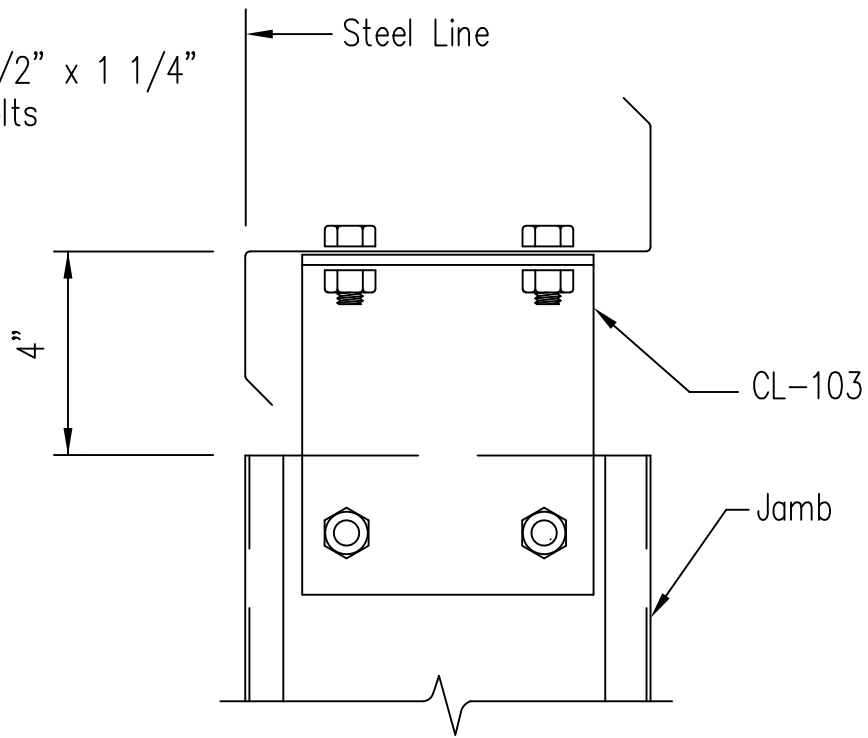

ERECTOR NOTE: IF CLIP BOXES ON BUILDING ELEVATION VIEW(S) ARE LEFT OF THE INTENDED JAMB LINE, THE CLIP(S) IN REFERENCE ARE TOED LEFT. IF RIGHT OF THE JAMB LINE, THEN TOED RIGHT. THE DRAWINGS ABOVE ARE TOED LEFT FOR REFERENCE.

Jamb to Girt

DRAWING NO.

SD93

NOTE:  
All Bolts are 1/2" x 1 1/4"  
A307 Mach. Bolts

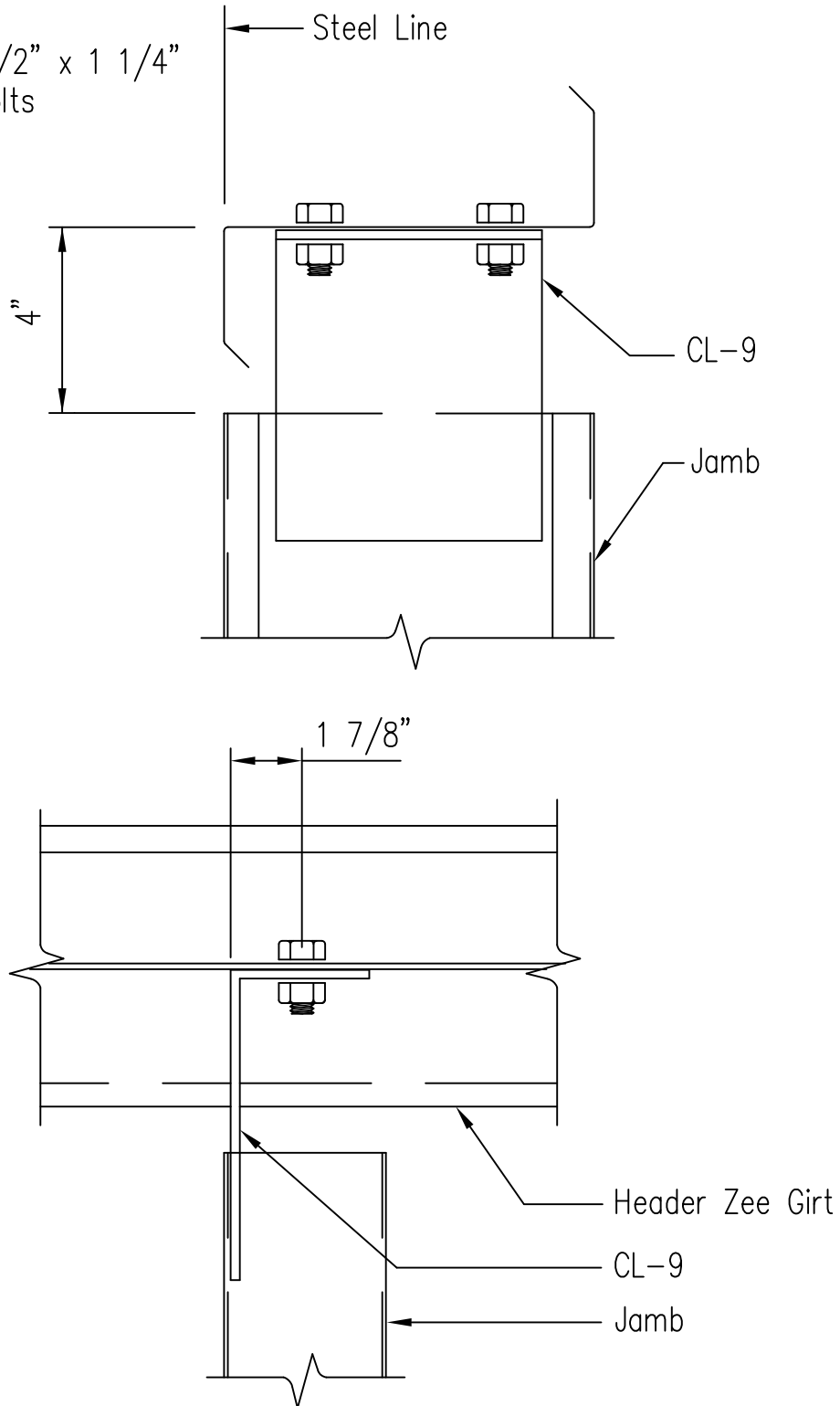

Jamb to Header Girt

DRAWING NO.

SD94

NOTE:

All Bolts are  $1/2''\phi \times 1\ 1/4''$   
A307 M. Bolts (UN Noted)

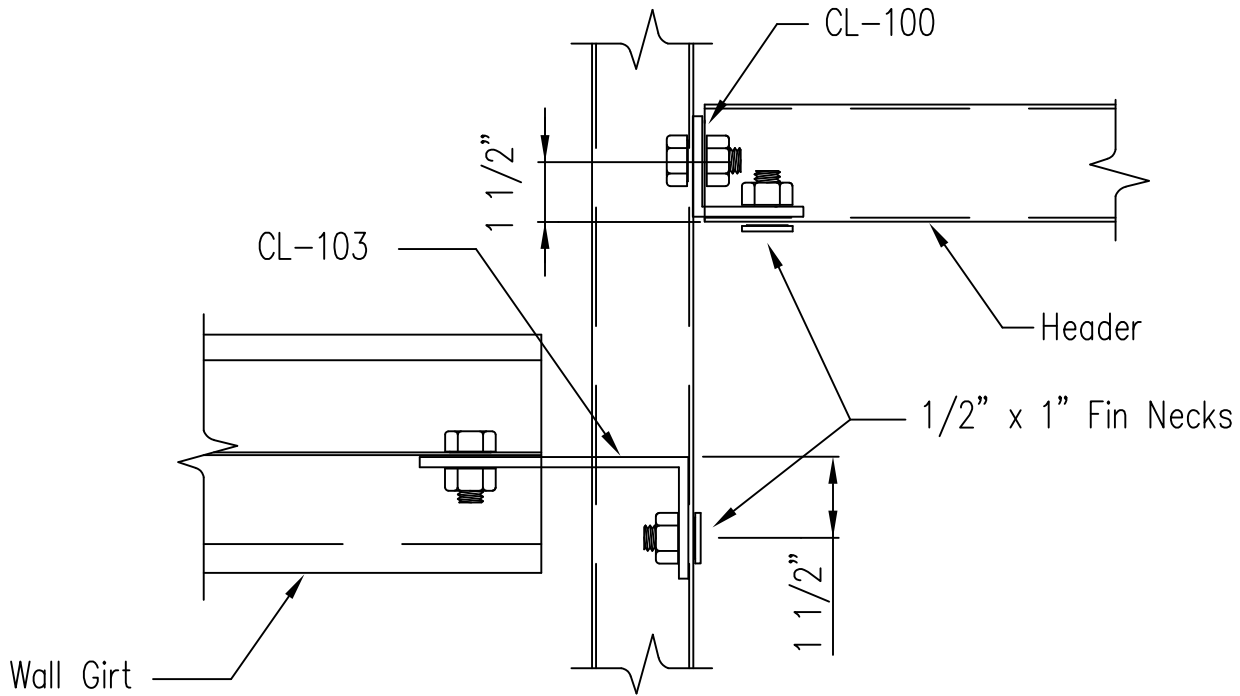
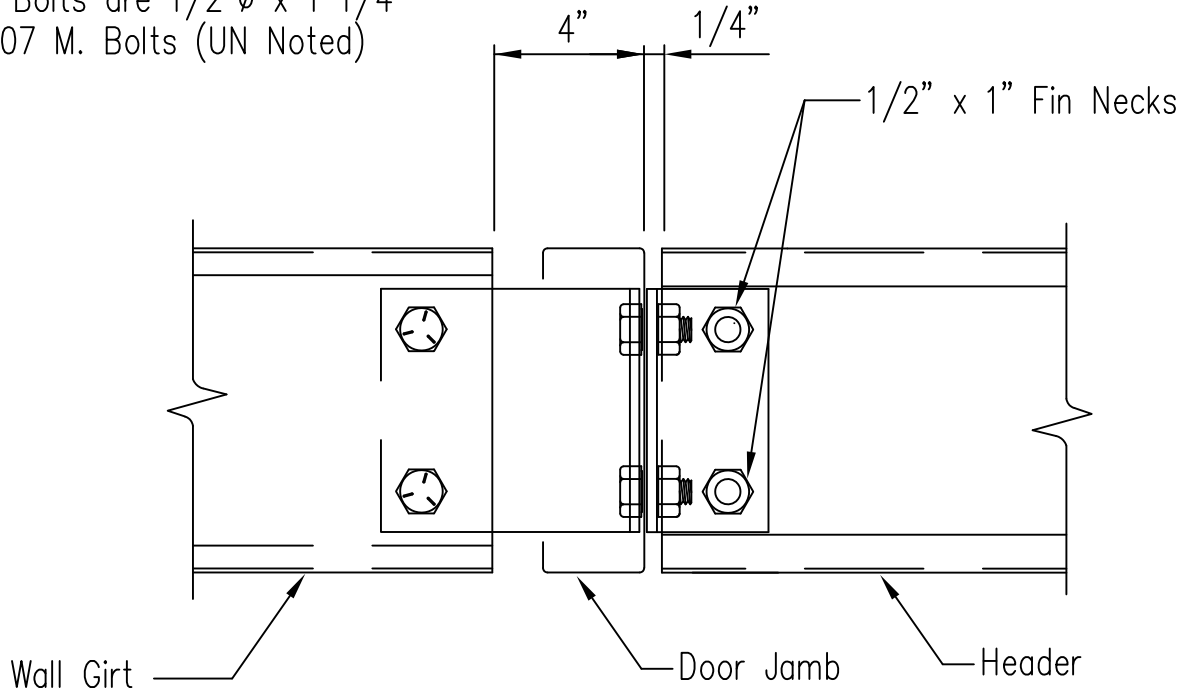

ERECTOR NOTE: IF CLIP BOXES ON BUILDING ELEVATION VIEW(S) ARE BELOW THE INTENDED GIRT LINE, THE CLIP(S) IN REFERENCE ARE TOED DOWN. IF ABOVE THE GIRT LINE, THEN TOED UP. THE DRAWINGS ABOVE ARE TOED DOWN FOR REFERENCE.

Girt/Header to Jamb

DRAWING NO.

SD95



NOTE:  
All Bolts are 1/2" x 1 1/4"  
A307 M. Bolts

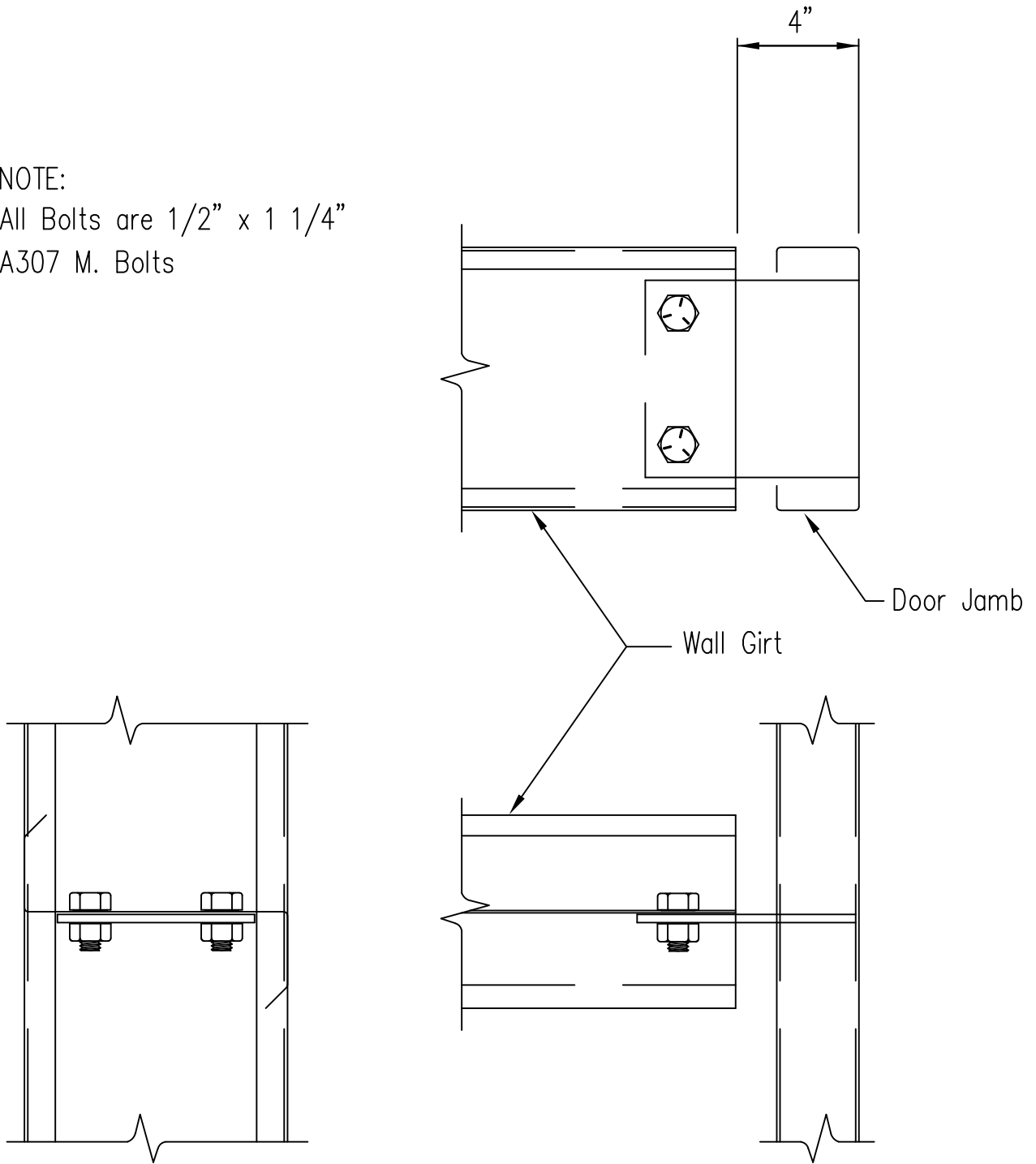

Girt to Jamb

DRAWING NO.

SD96

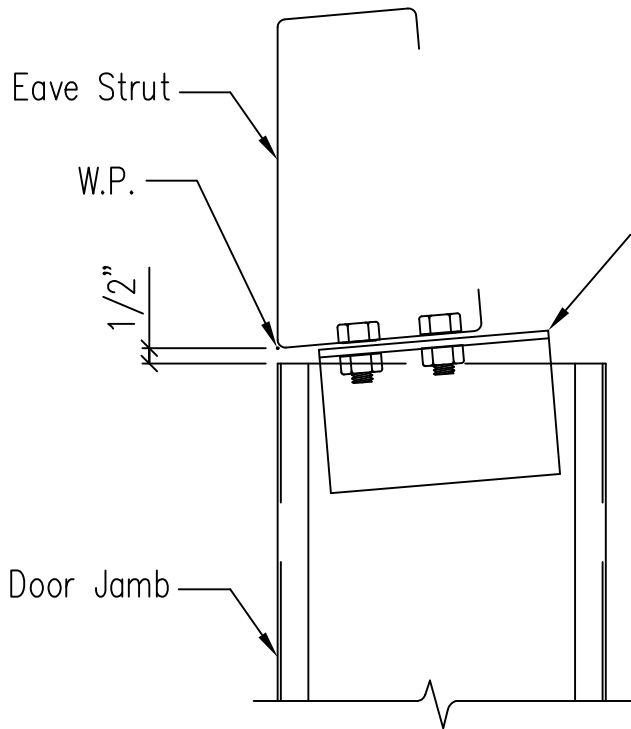

Eave Strut  
To Jamb Clip  
CL-8

NOTE:  
All Bolts are 1/2" x 1 1/4"  
A307 Mach. Bolts

Door Jamb

Low Eave Condition

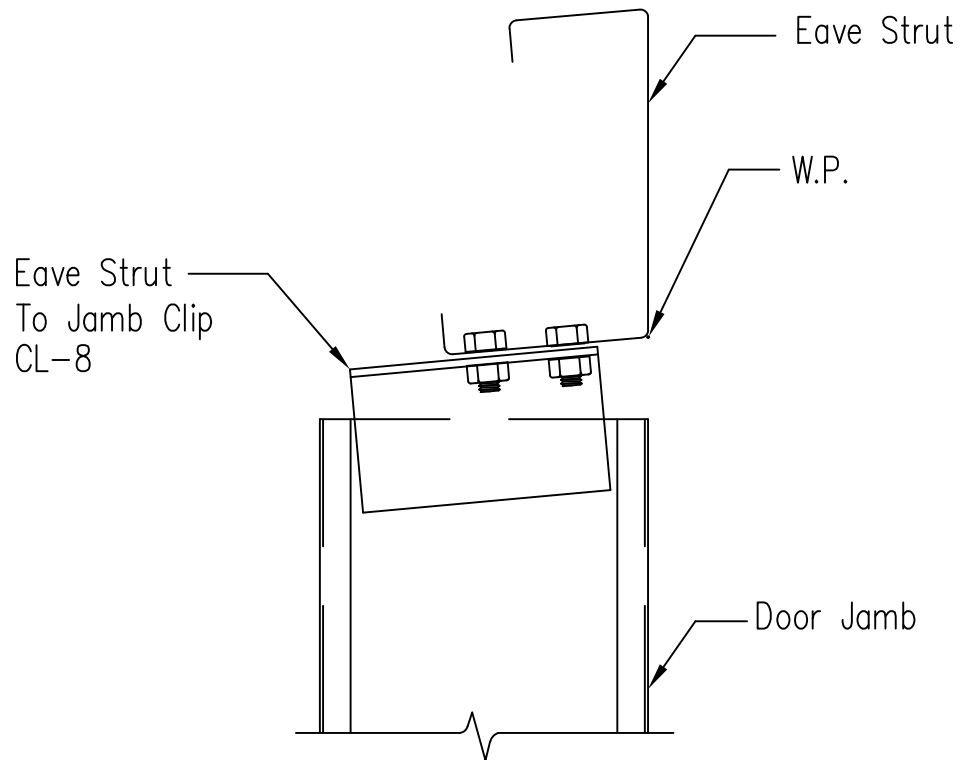

Eave Strut  
To Jamb Clip  
CL-8

Eave Strut

W.P.

Door Jamb

High Eave Condition

Jamb To Eave Strut  
2:12 Roof Pitch and Higher

DRAWING NO.

SD97

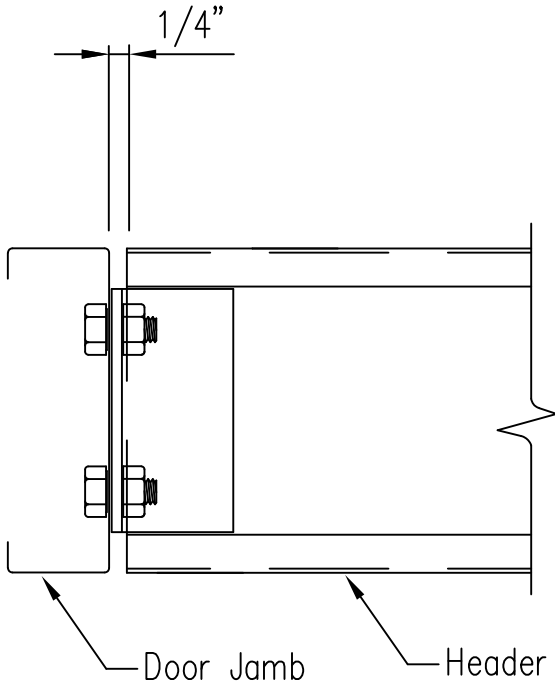

Option 1

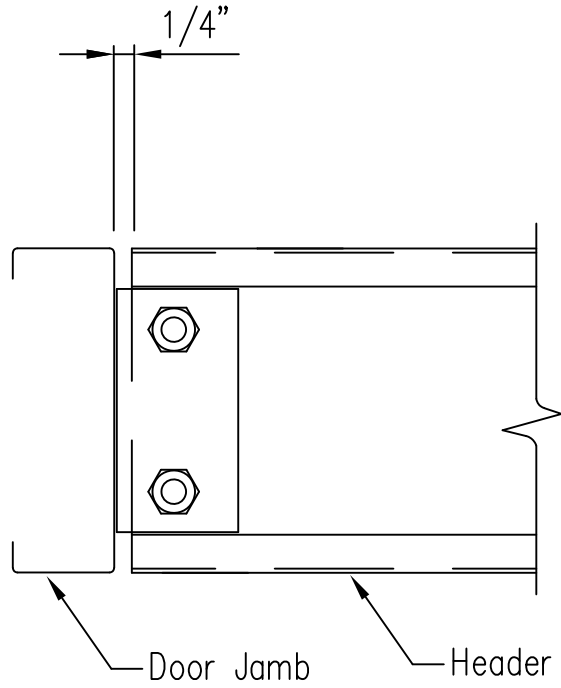

Option 2

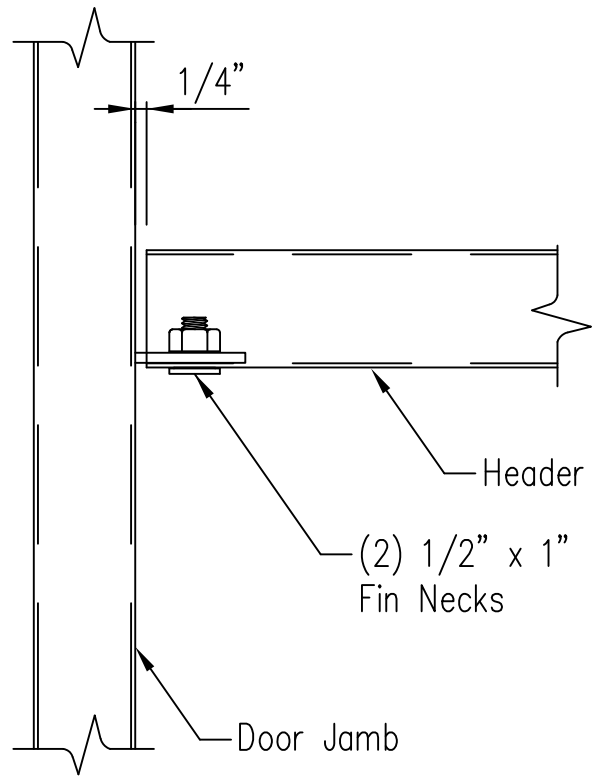
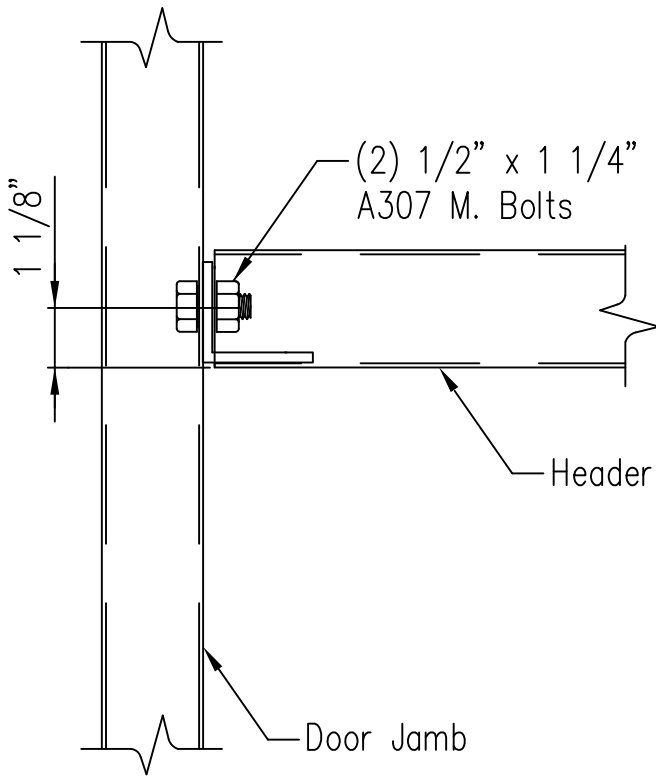

Header/Sill to Jamb

DRAWING NO.

SD98

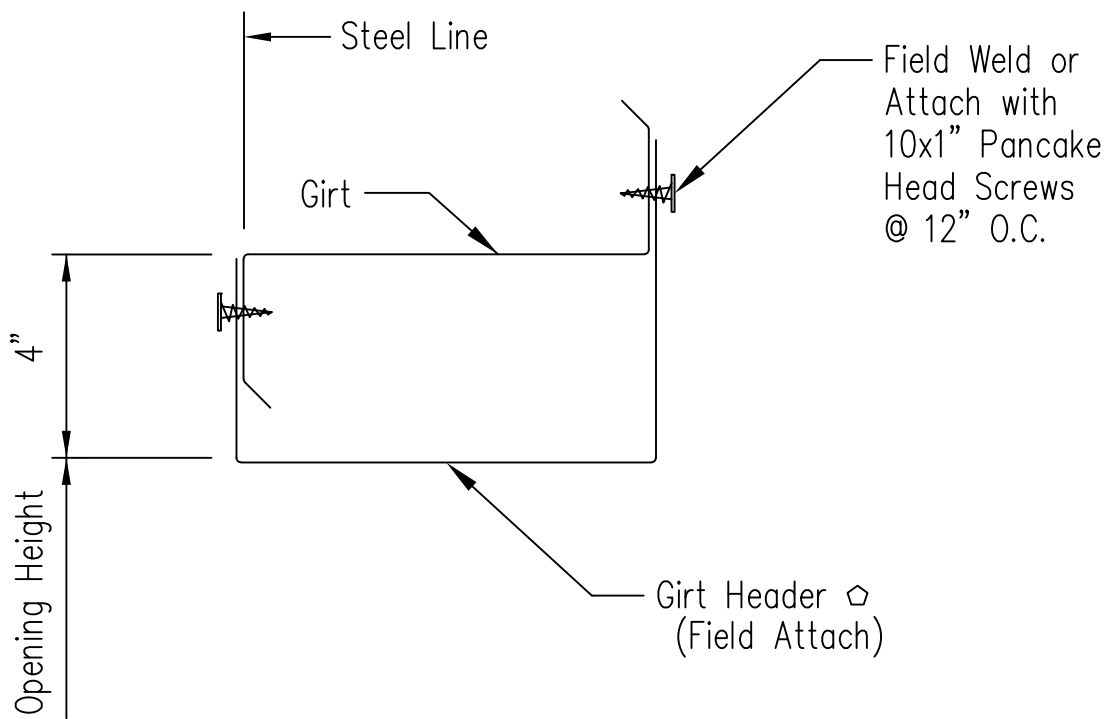

◊ MEMBER TABLE	
ZEE Size	Piece Mark
8"	GH-1
10"	GH-2
12"	GH-3

Framed Opening w/ Girt Header

DRAWING NO.

SD104

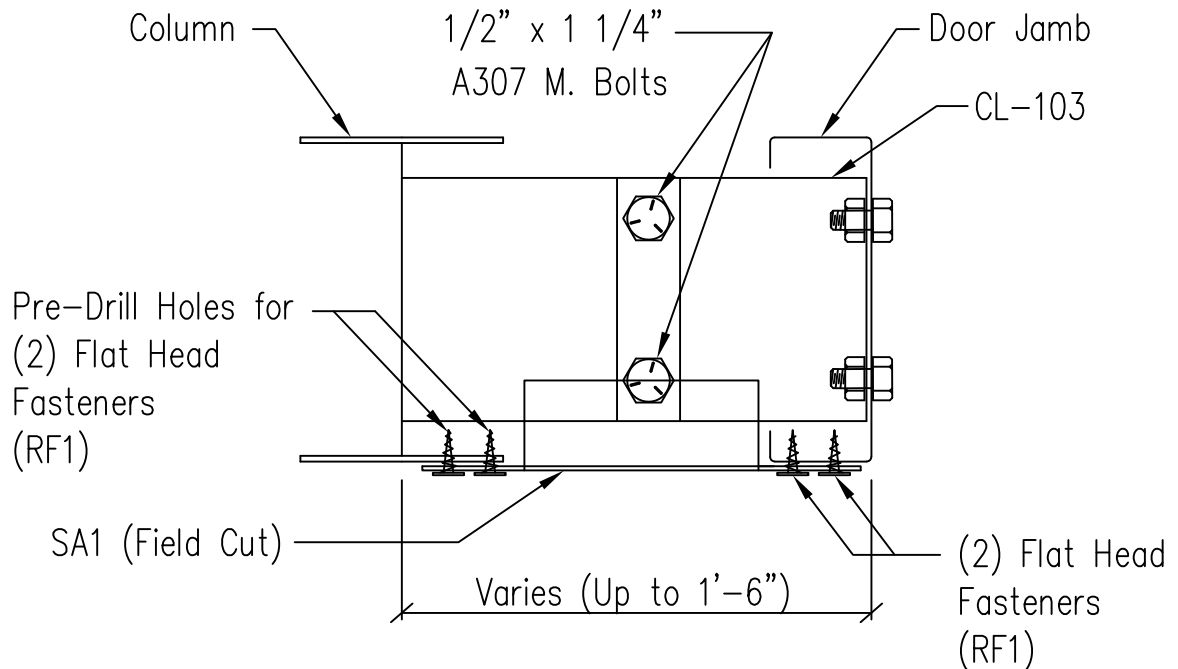
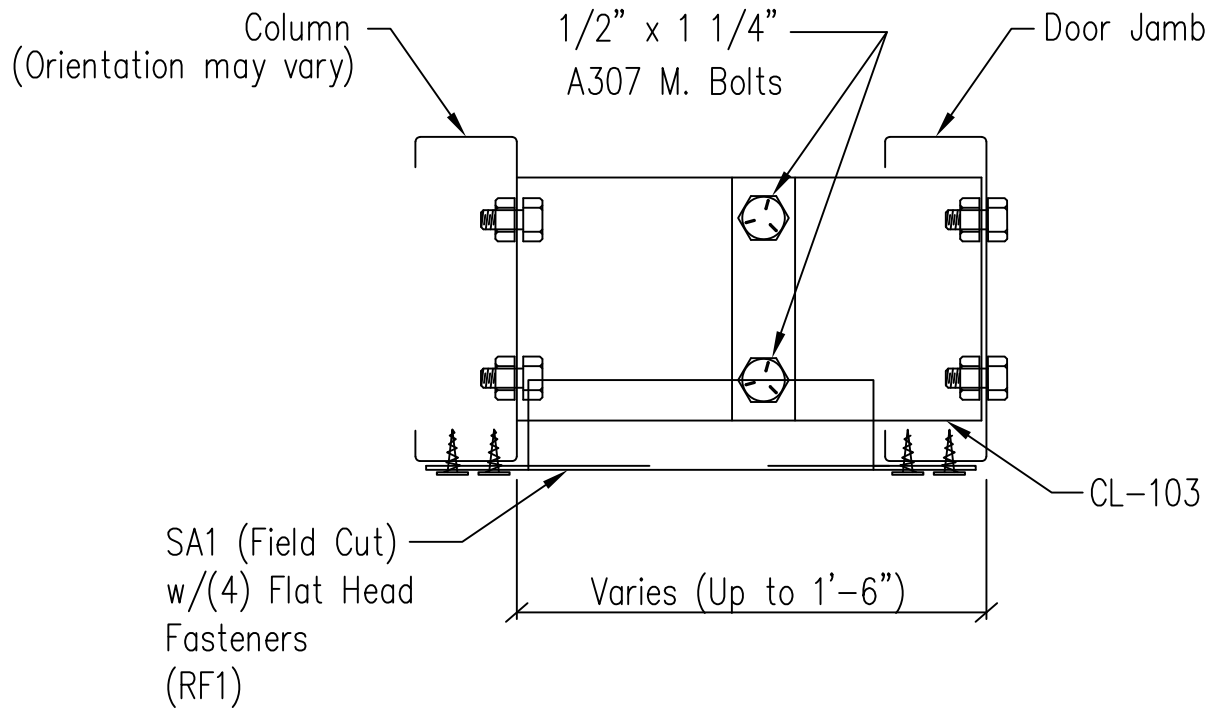

# Column to Door Jamb Clip Attachment

DRAWING NO.

SD113

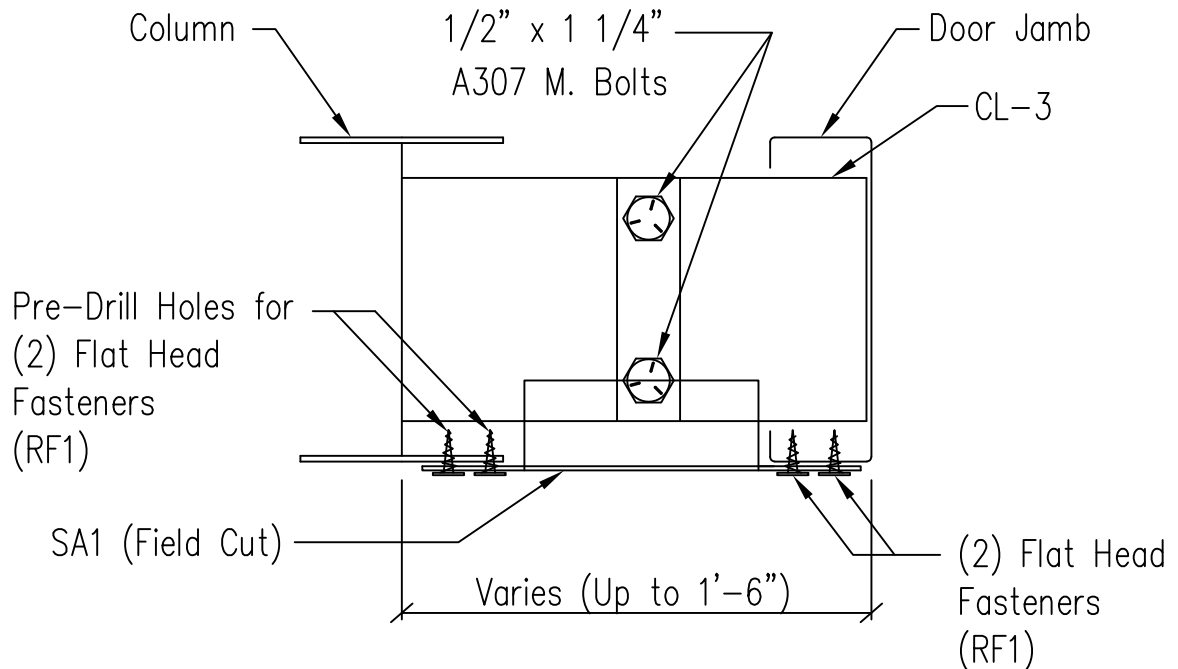
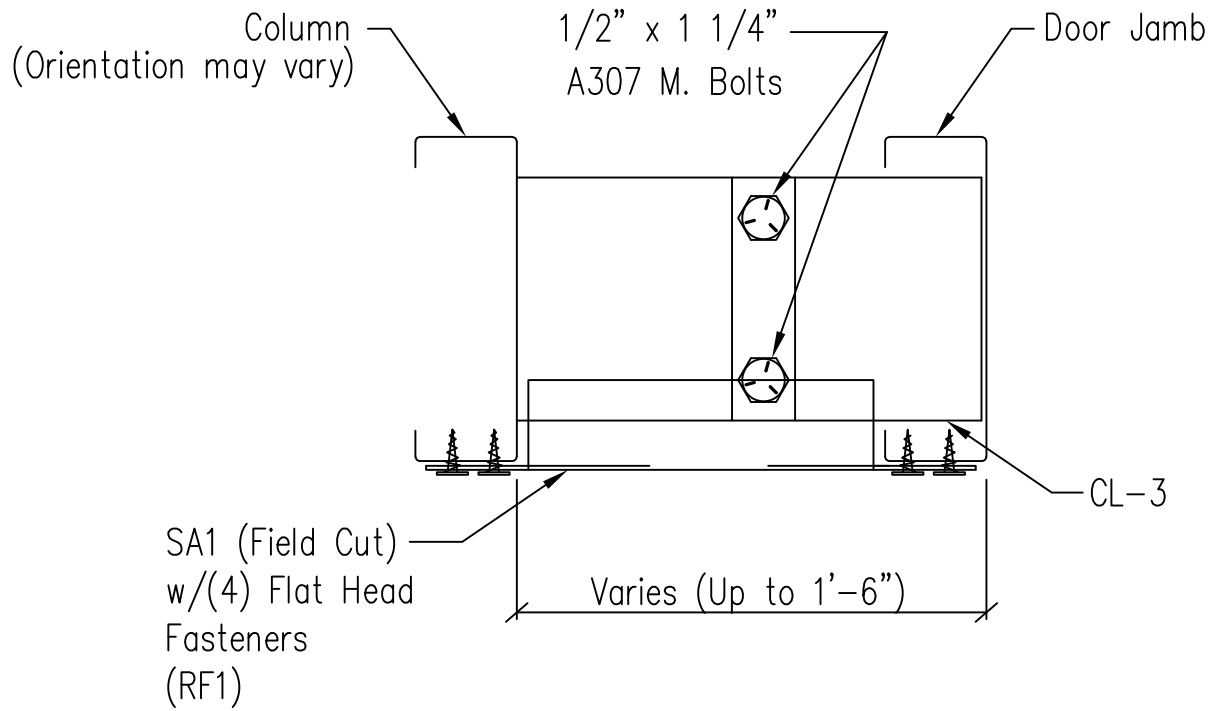

# Column to Door Jamb Clip Attachment

DRAWING NO.

SD114

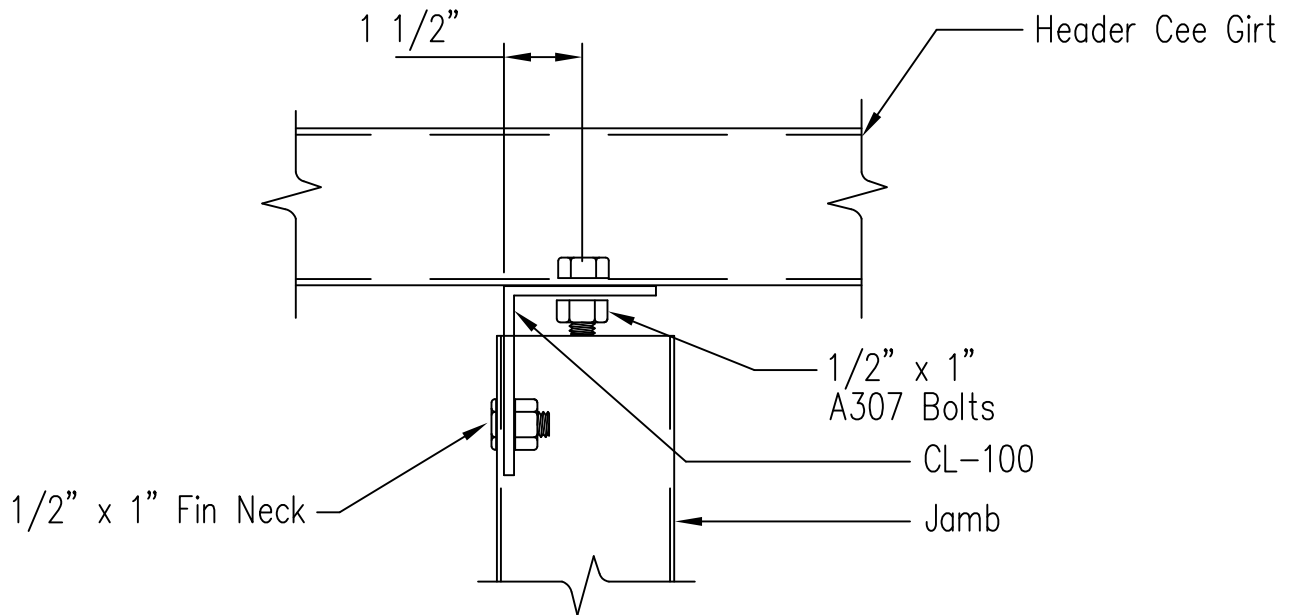
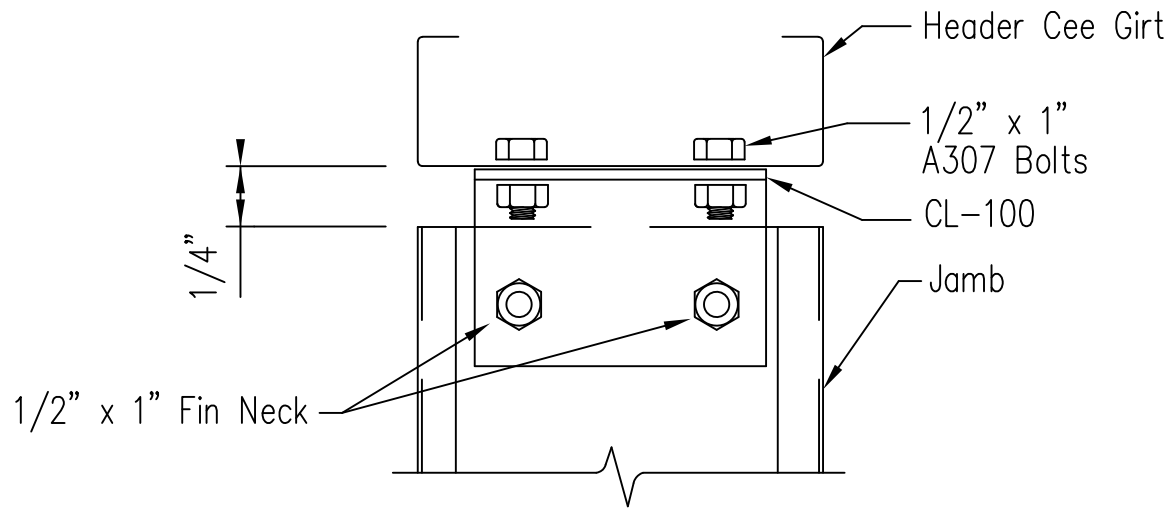

Jamb to Header Girt

DRAWING NO.

SD122

NOTE:

All Bolts are 1/2" x 1 1/4"

A307 M. Bolt

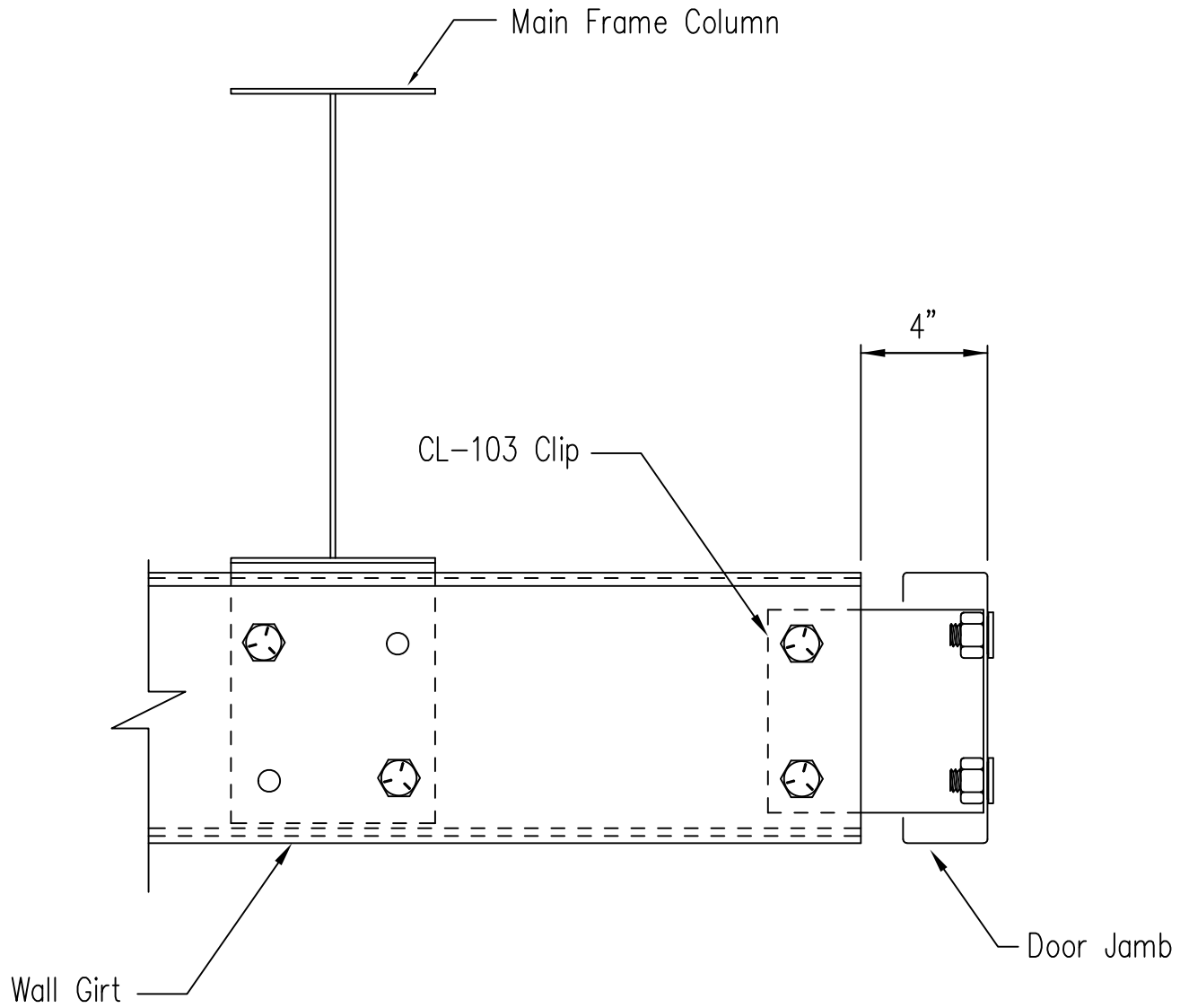

ERECTOR NOTE: IF CLIP BOXES ON BUILDING ELEVATION VIEW(S) ARE BELOW THE INTENDED GIRT LINE, THE CLIP(S) IN REFERENCE ARE TOED DOWN. IF ABOVE THE GIRT LINE, THEN TOED UP.

No Lap Near Framed Opening

DRAWING NO.

SD166