

Section Thru Rake at Cold-Form Rafter

DRAWING NO.

SD1

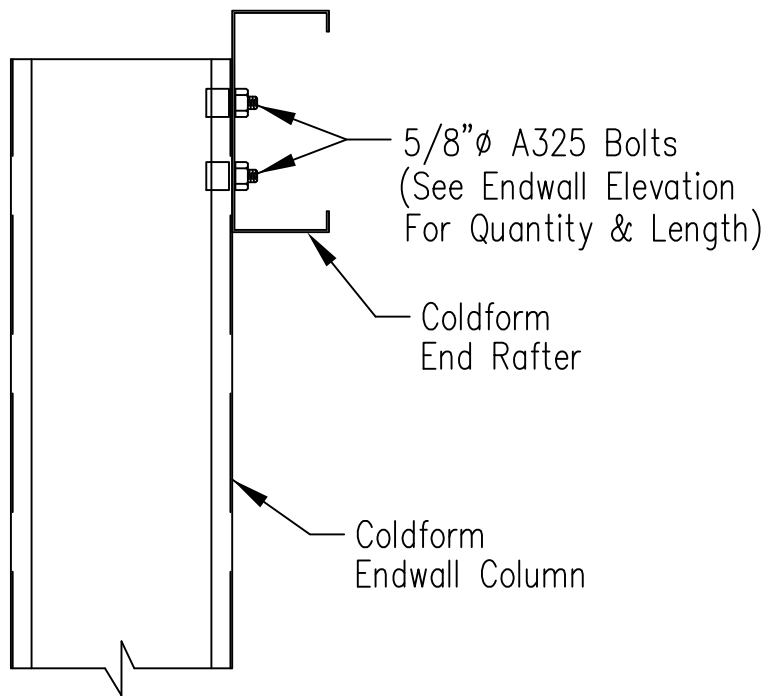
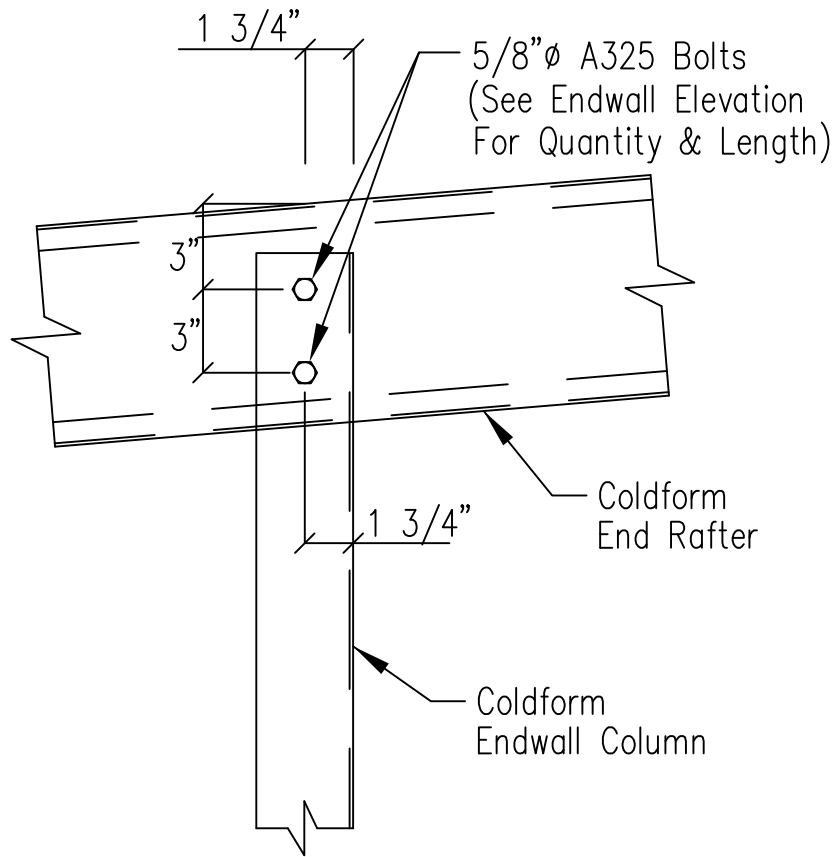

Cold Form Column to Cold Form Rafter

DRAWING NO.

SD2

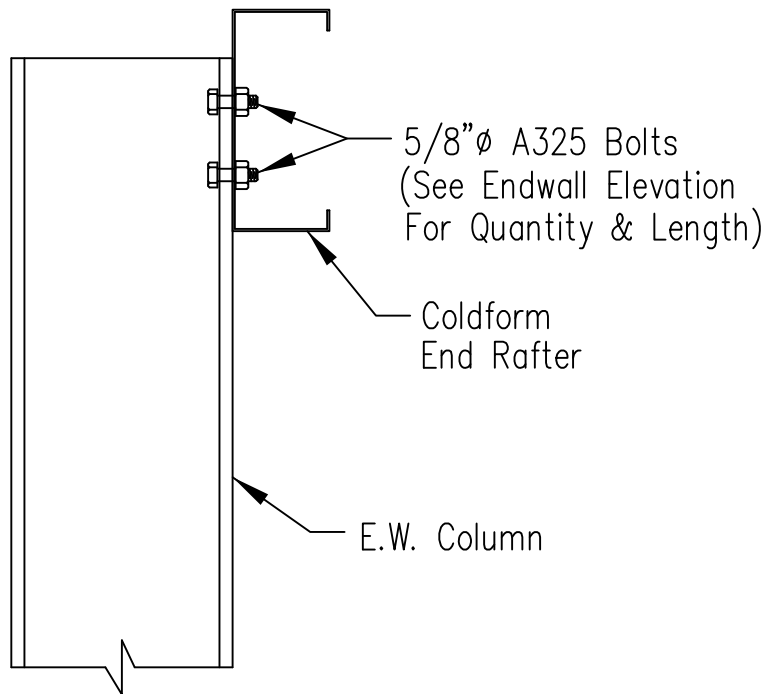
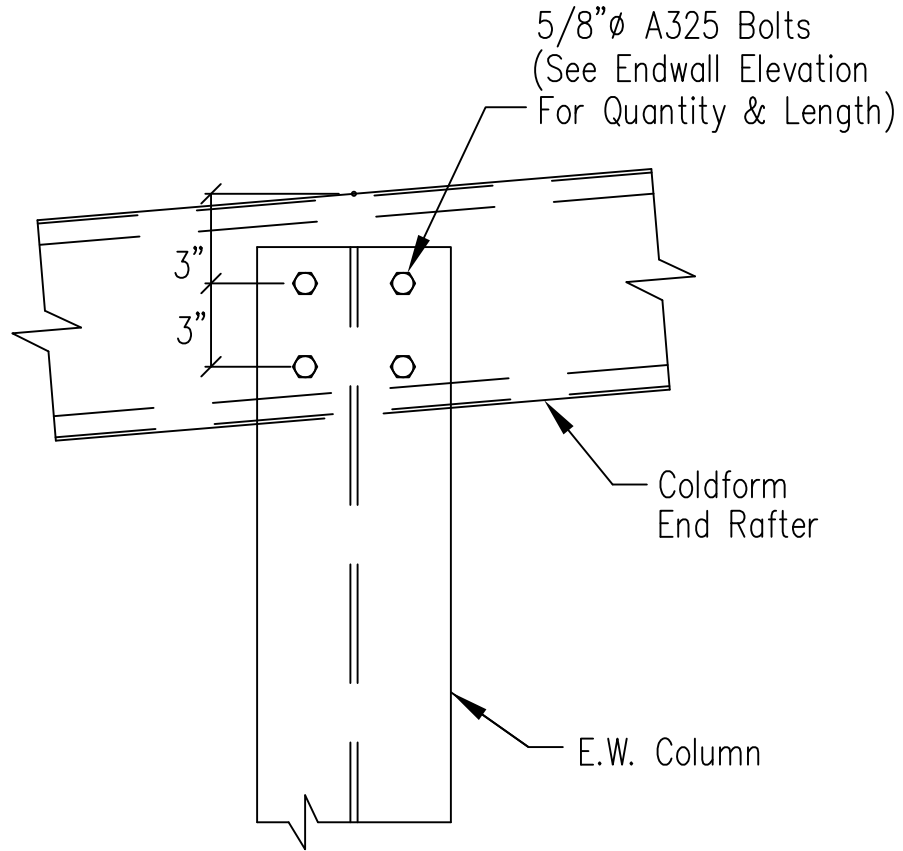

Hot Rolled Column to Cold Form Rafter

DRAWING NO.

SD3

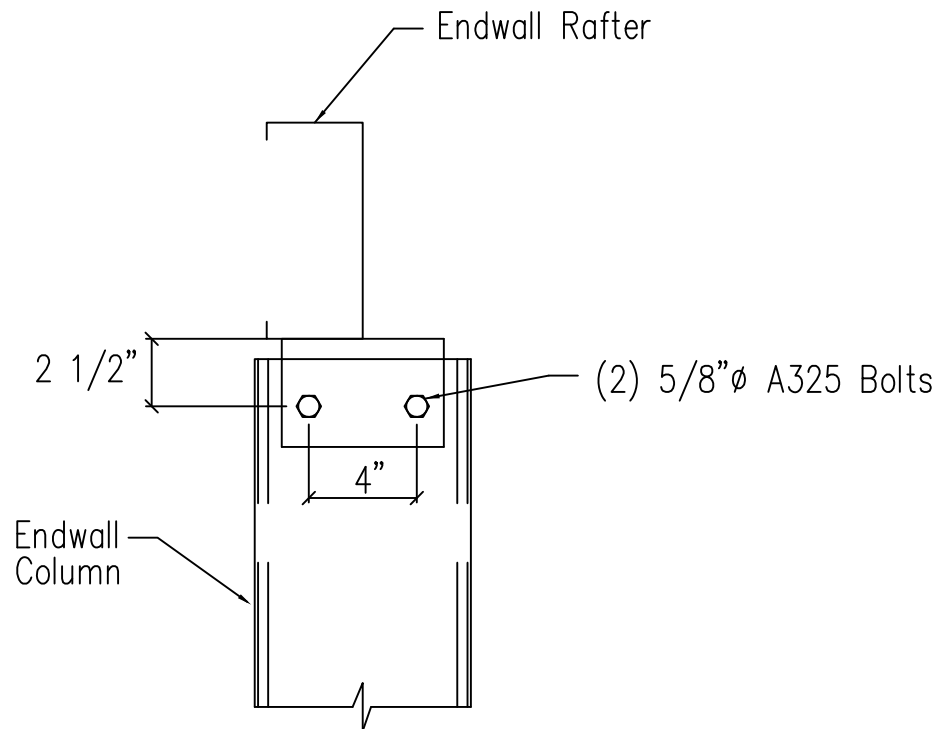
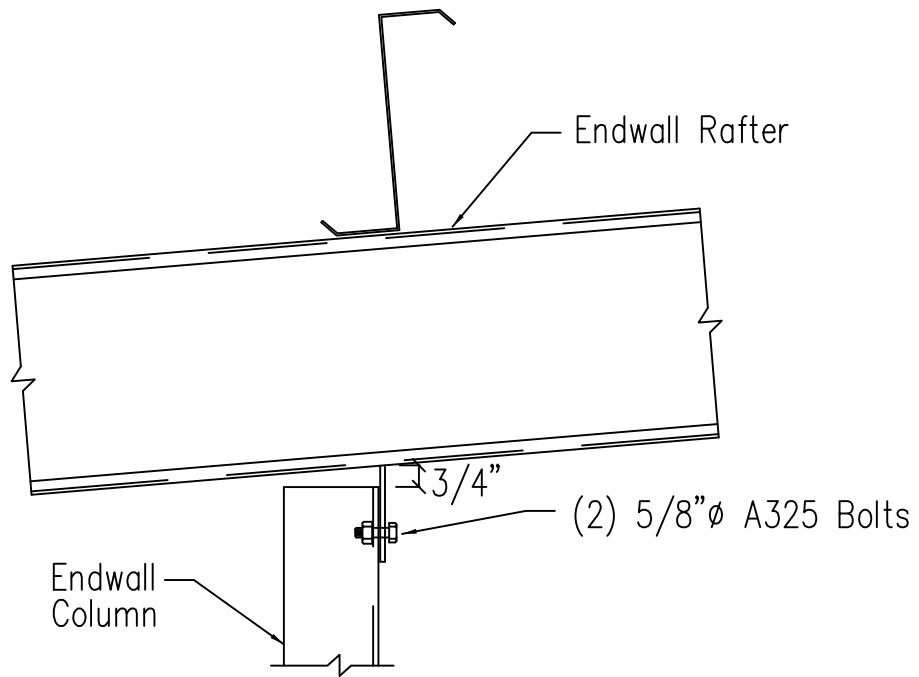

Cold Form Column to Cold Form Rafter

DRAWING NO.

SD4

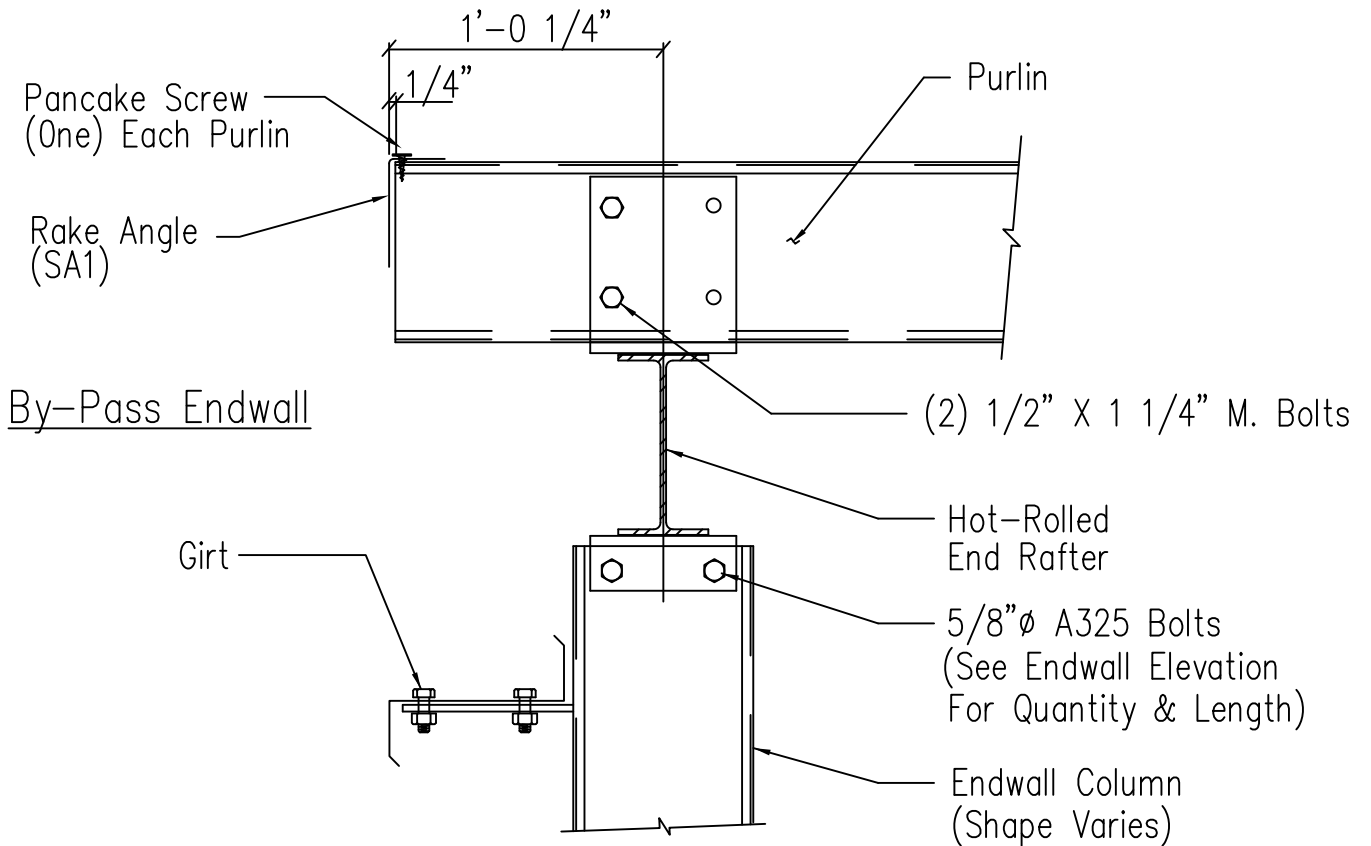
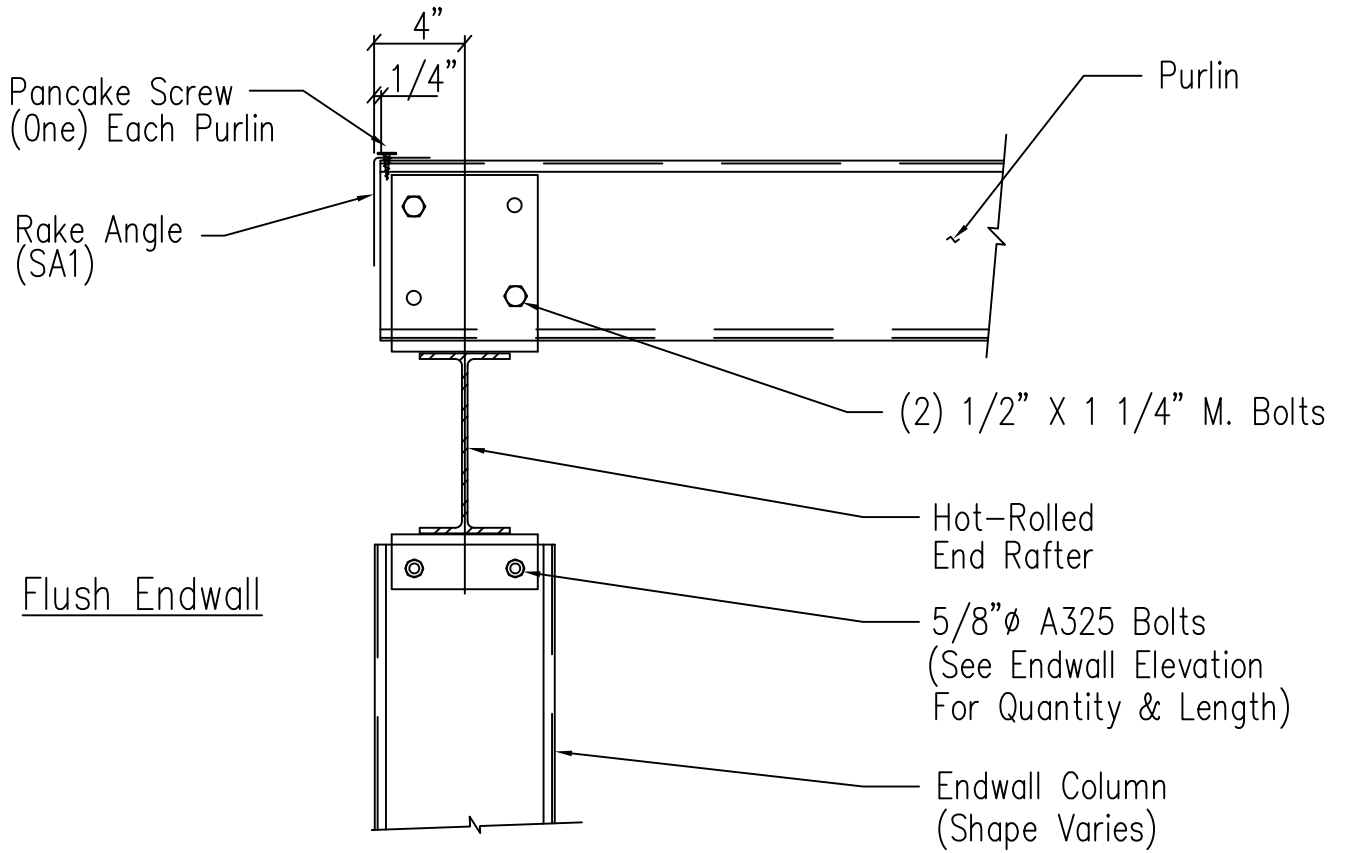

Section Thru Rake w/Hot Rolled Rafter

DRAWING NO.

SD5

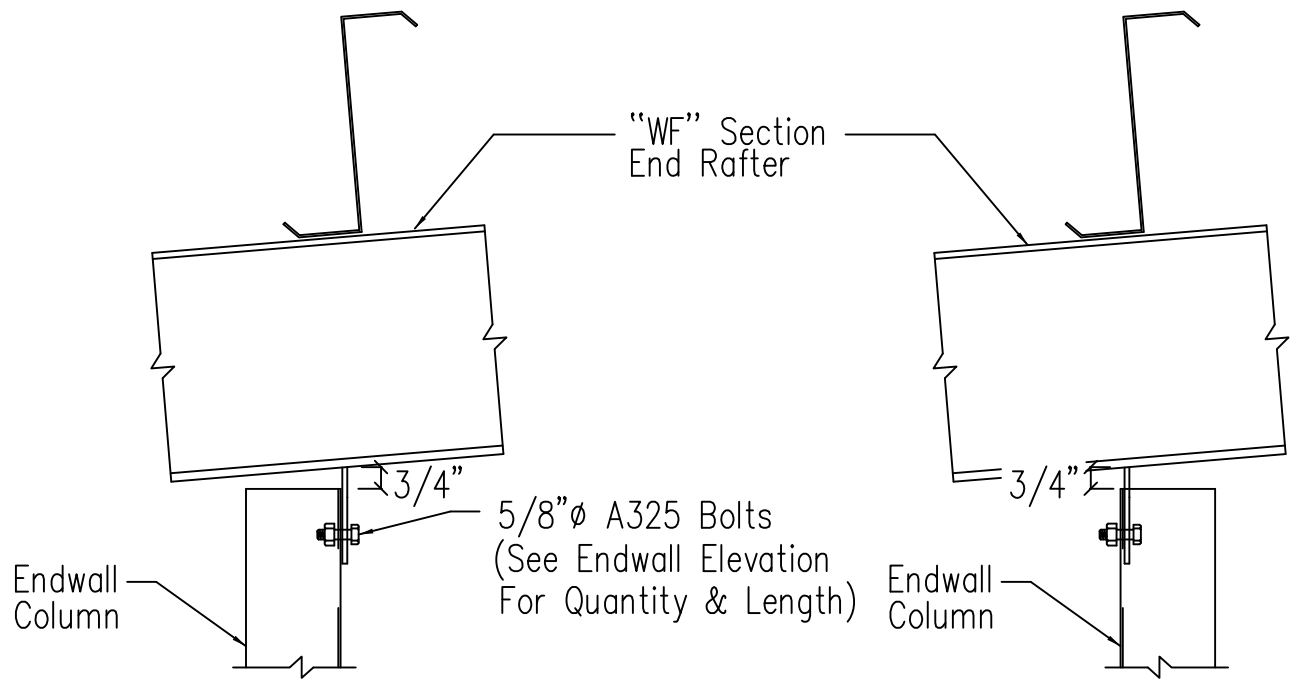

Cee Endwall Column
Toes Toward Downslope

Cee Endwall Column
Toes Toward Upslope

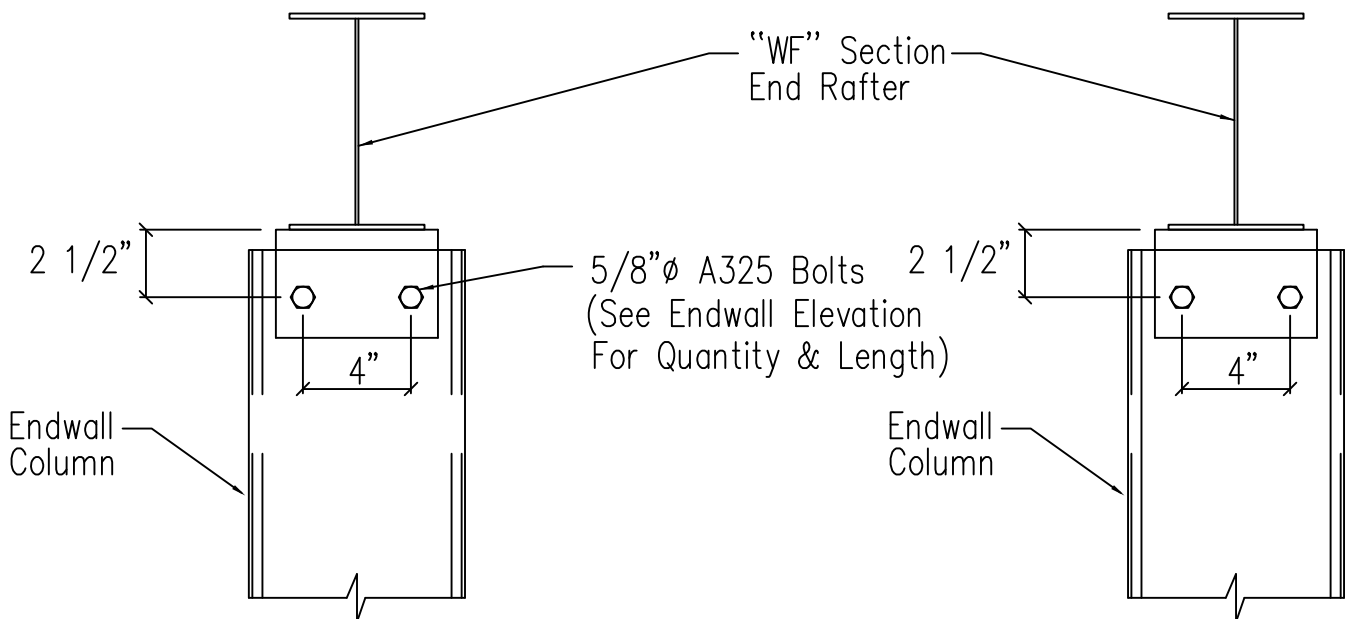

Cold Form Column to Hot Rolled Rafter

DRAWING NO.

SD6

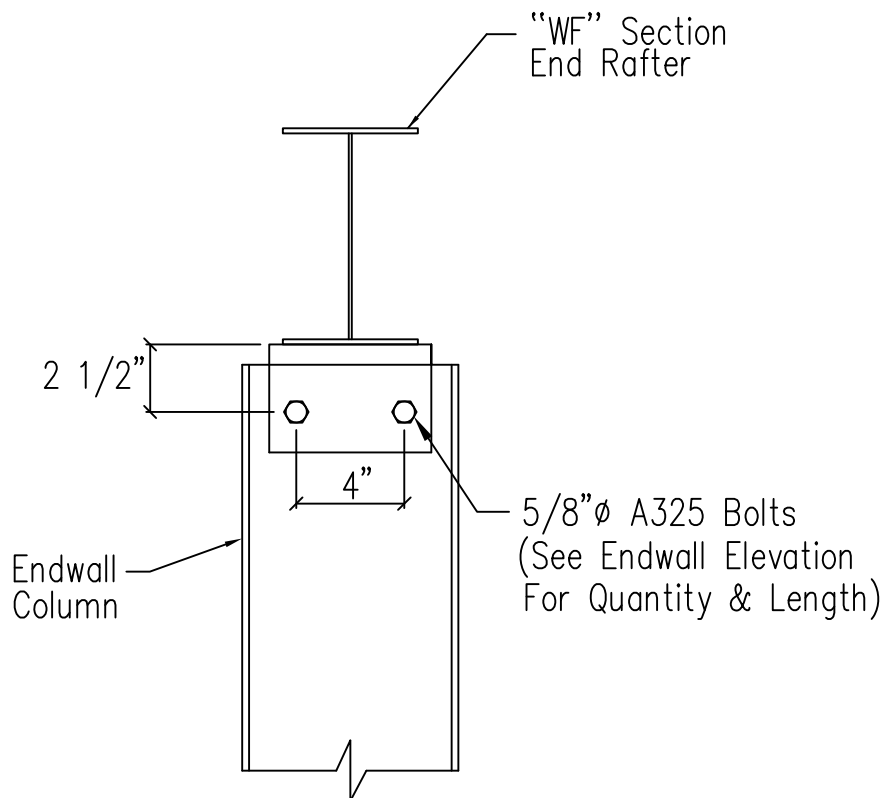
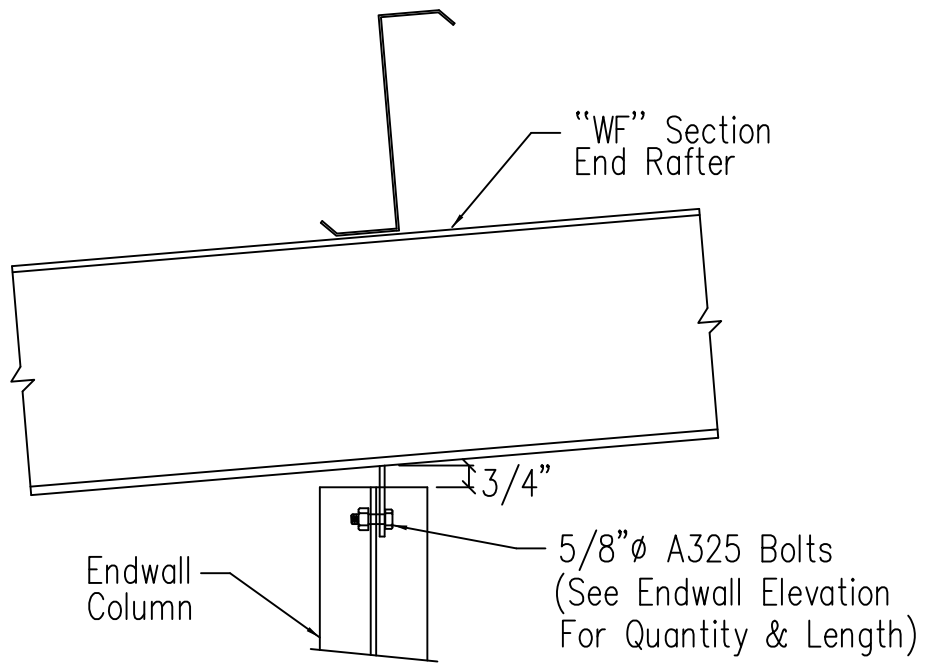

Hot Rolled Column to Hot Rolled Rafter

DRAWING NO.

SD7

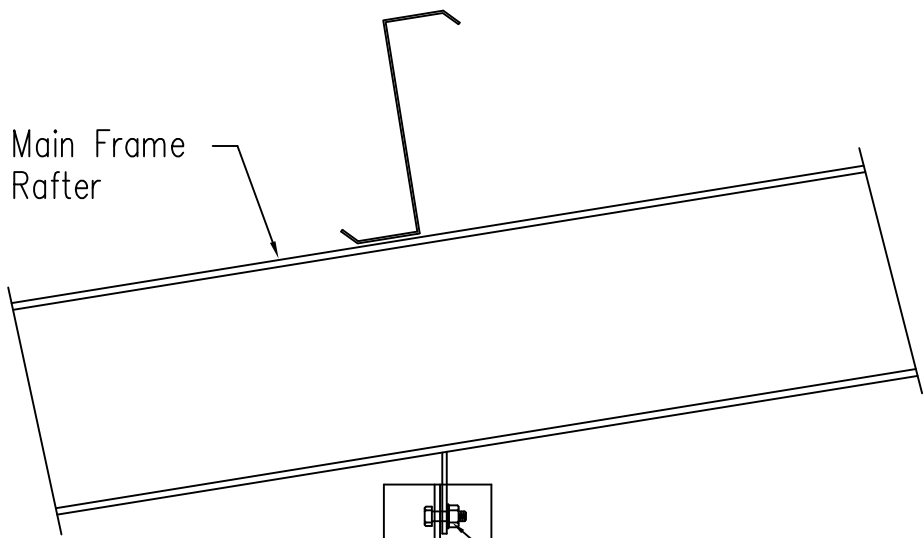

Main Frame Rafter

Interior Column

5/8" ϕ A325 Bolts
(See Endwall Elevation
For Quantity & Length)
w/ Flat Washers

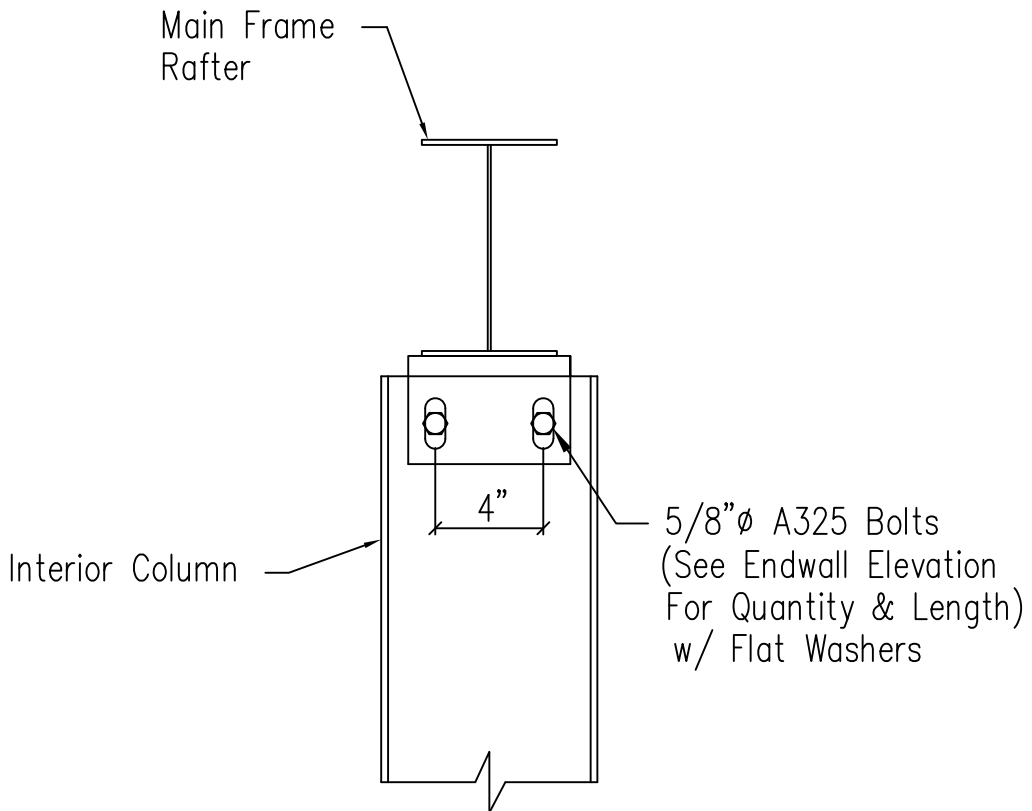

Main Frame Rafter

Interior Column

5/8" ϕ A325 Bolts
(See Endwall Elevation
For Quantity & Length)
w/ Flat Washers

4"

Hot Rolled Column to Main Frame Rafter

DRAWING NO.

SD8

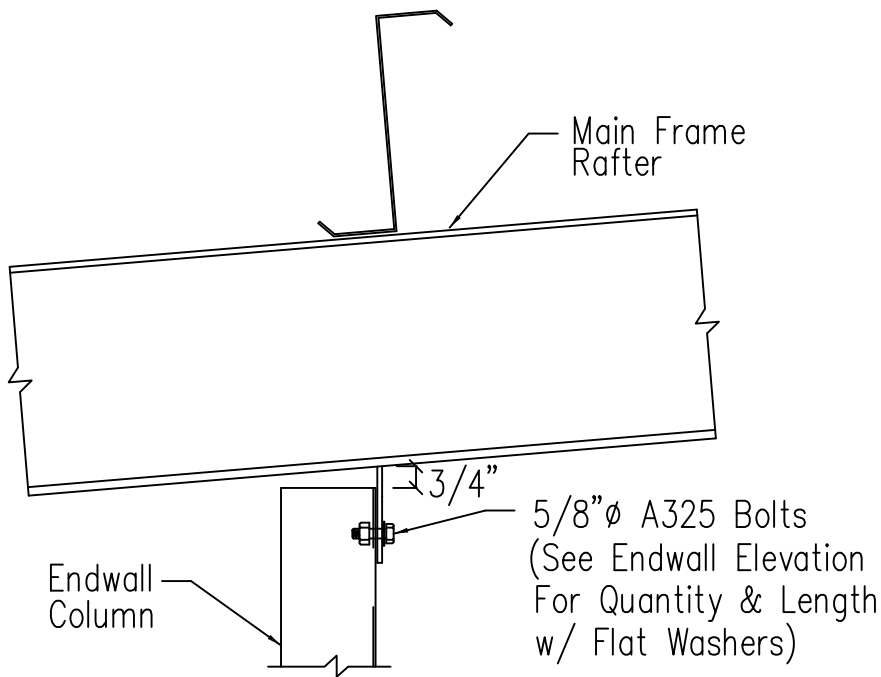

Cee Endwall Column
Toes Toward Downslope

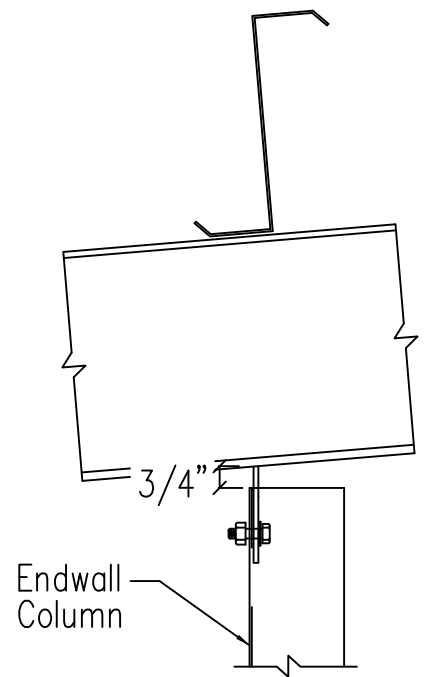

Cee Endwall Column
Toes Toward Upslope

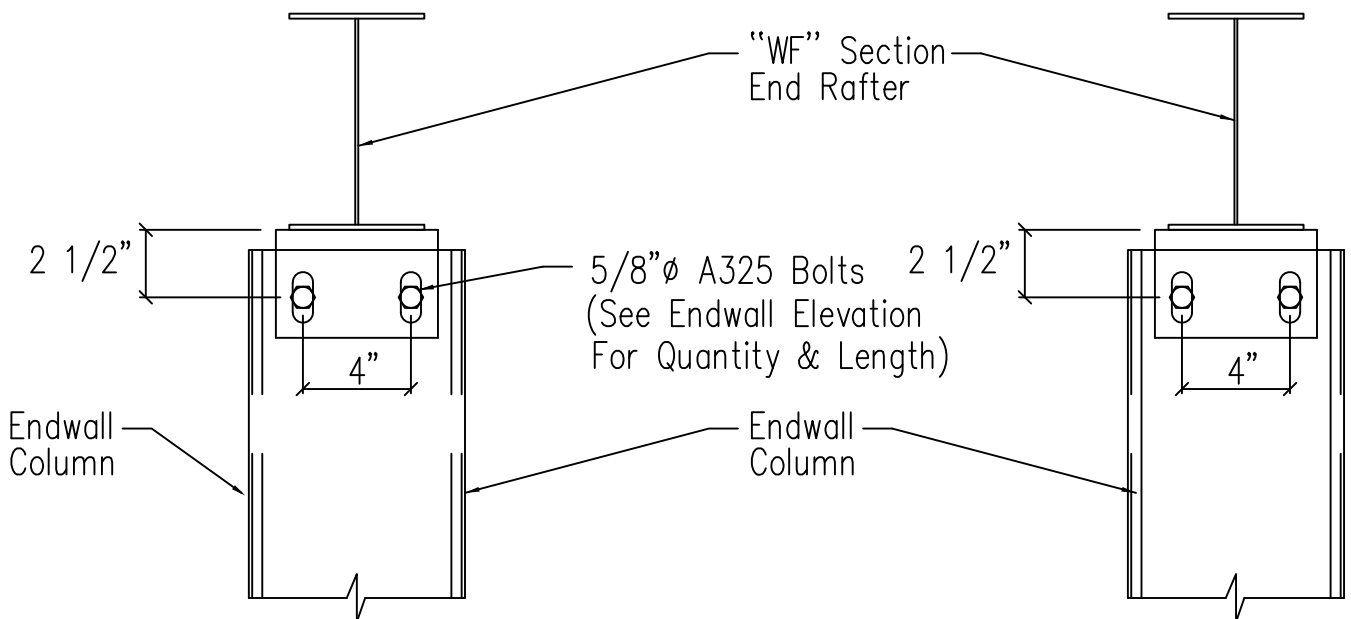

Cold Form Column to Main Frame Rafter

DRAWING NO.

SD8

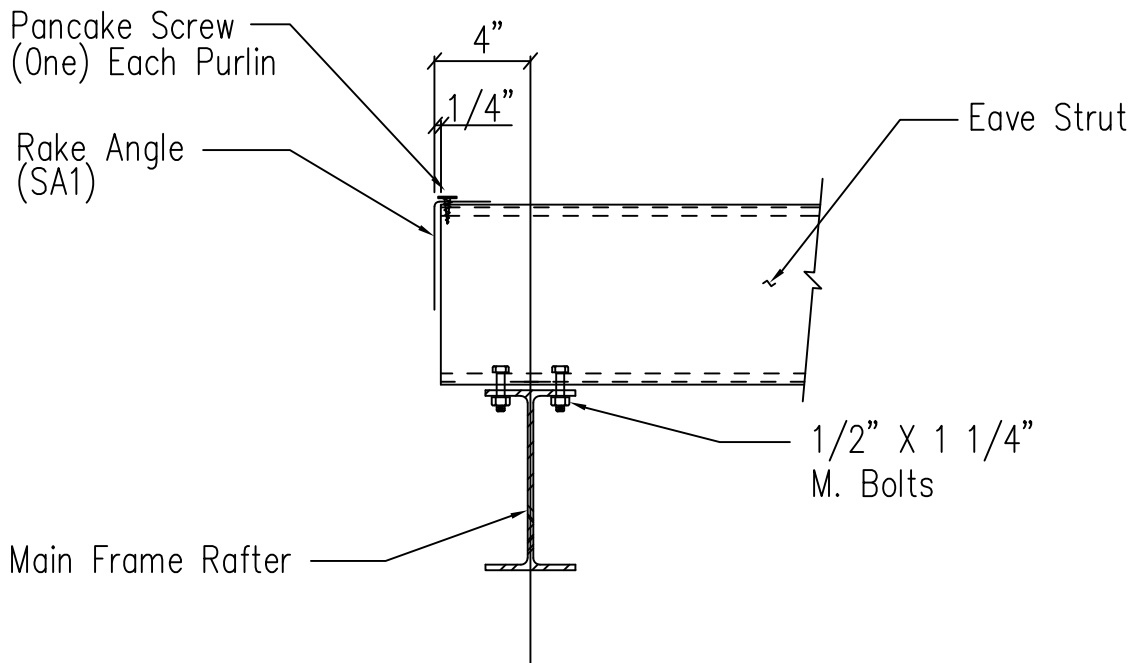
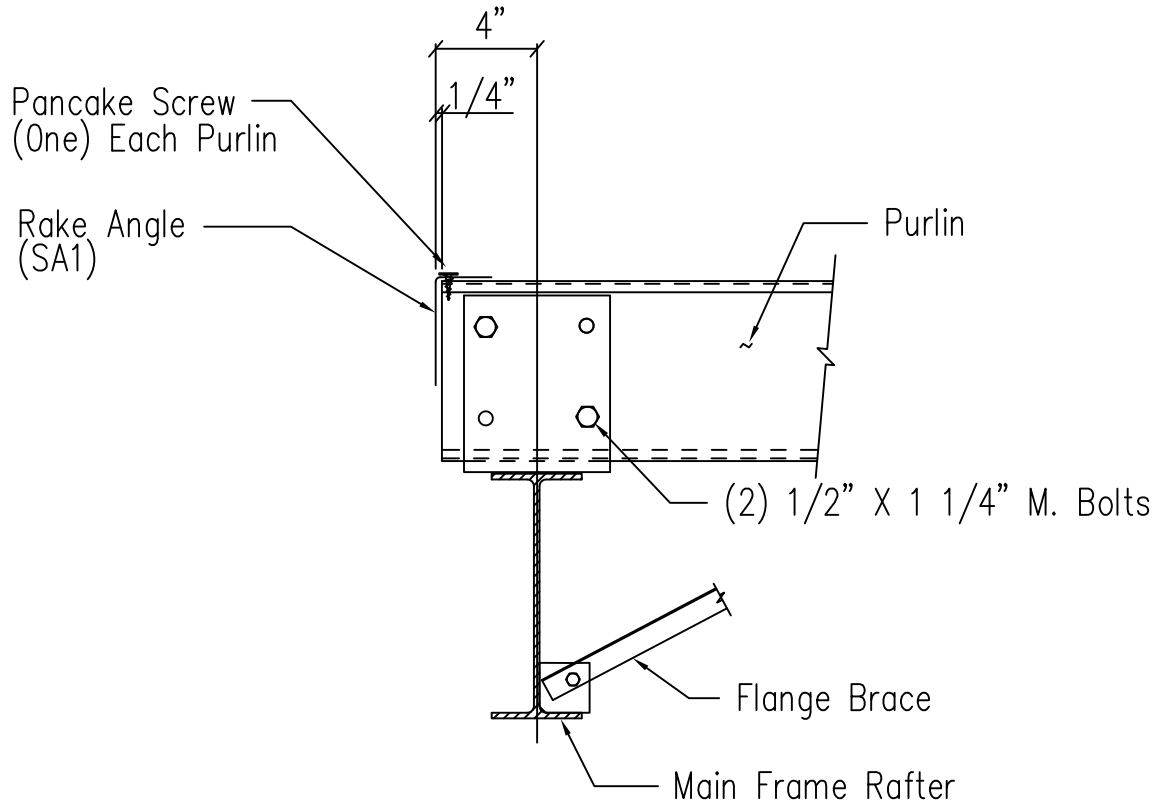

Main Frame Rafter Connection
PURLIN & EAVE STRUT CONNECTION

DRAWING NO.

SD9

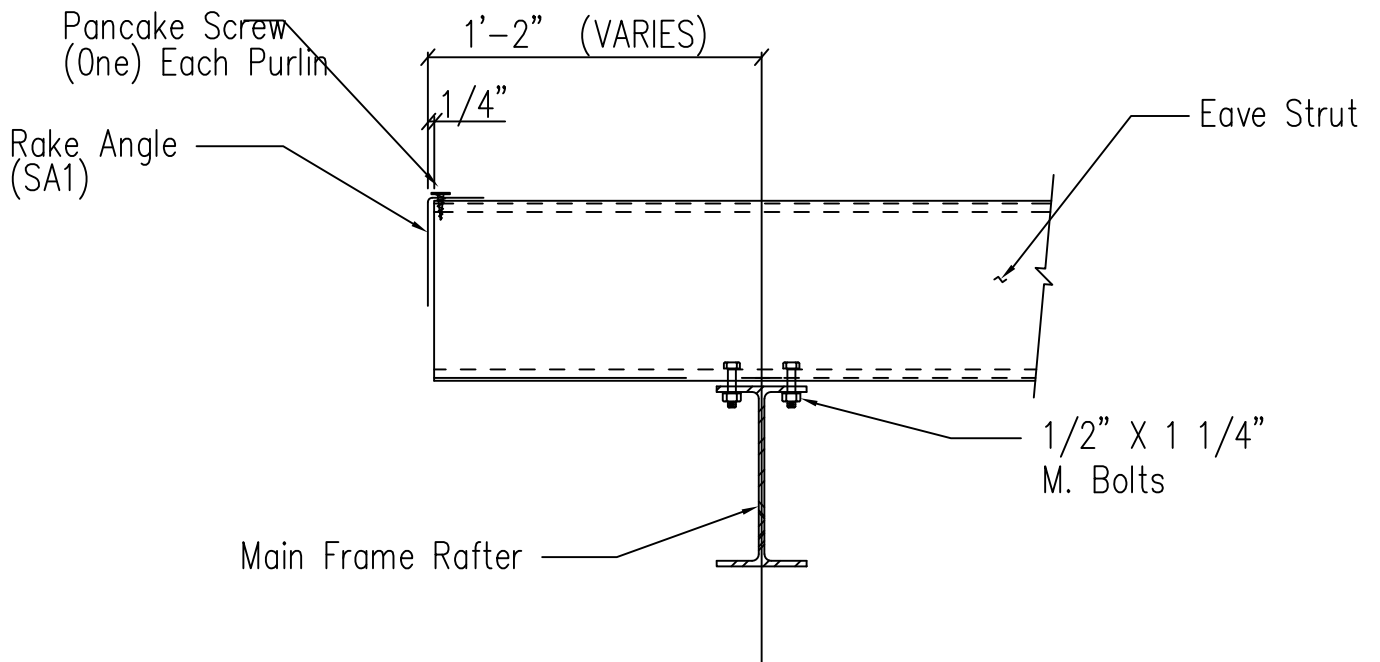
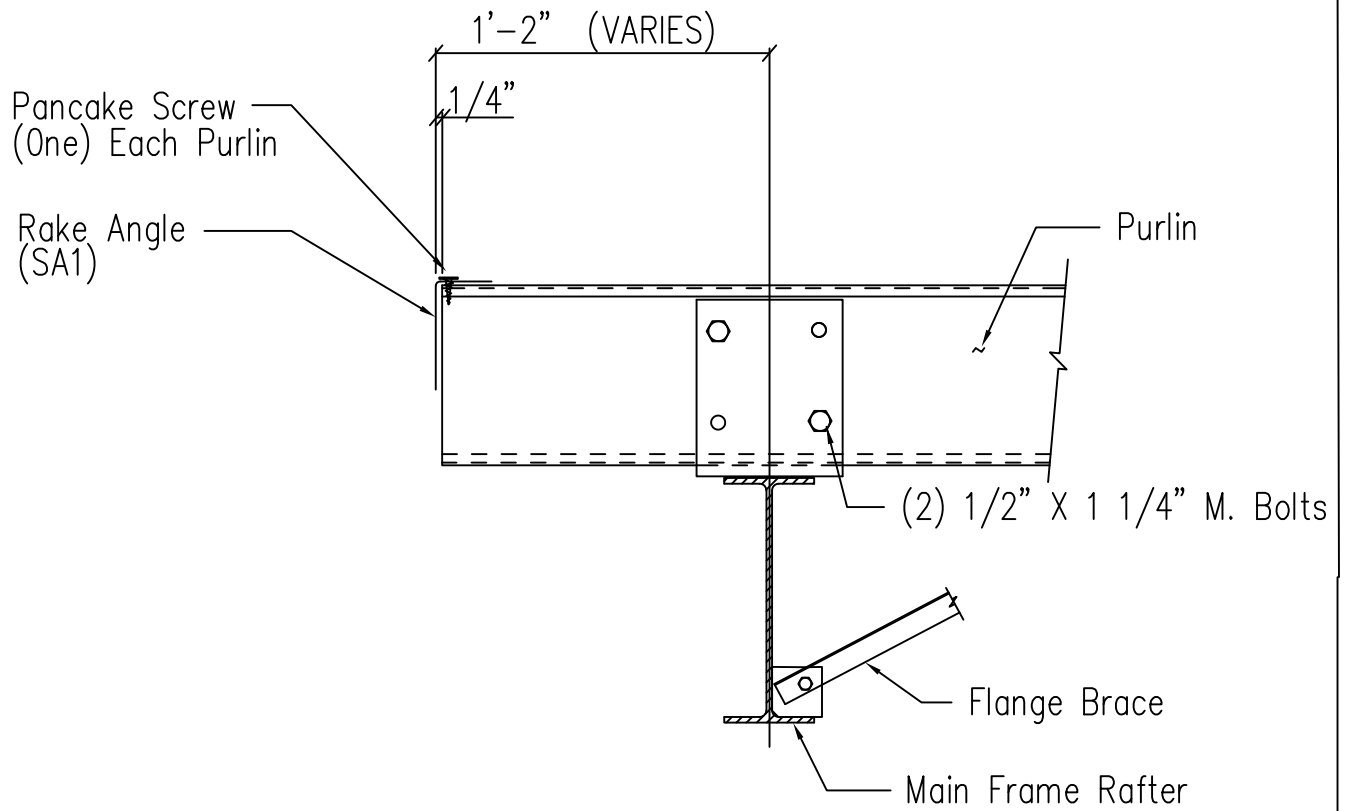

Main Frame Rafter Connection
 PURLIN & EAVE STRUT CONNECTION

DRAWING NO.
SD10

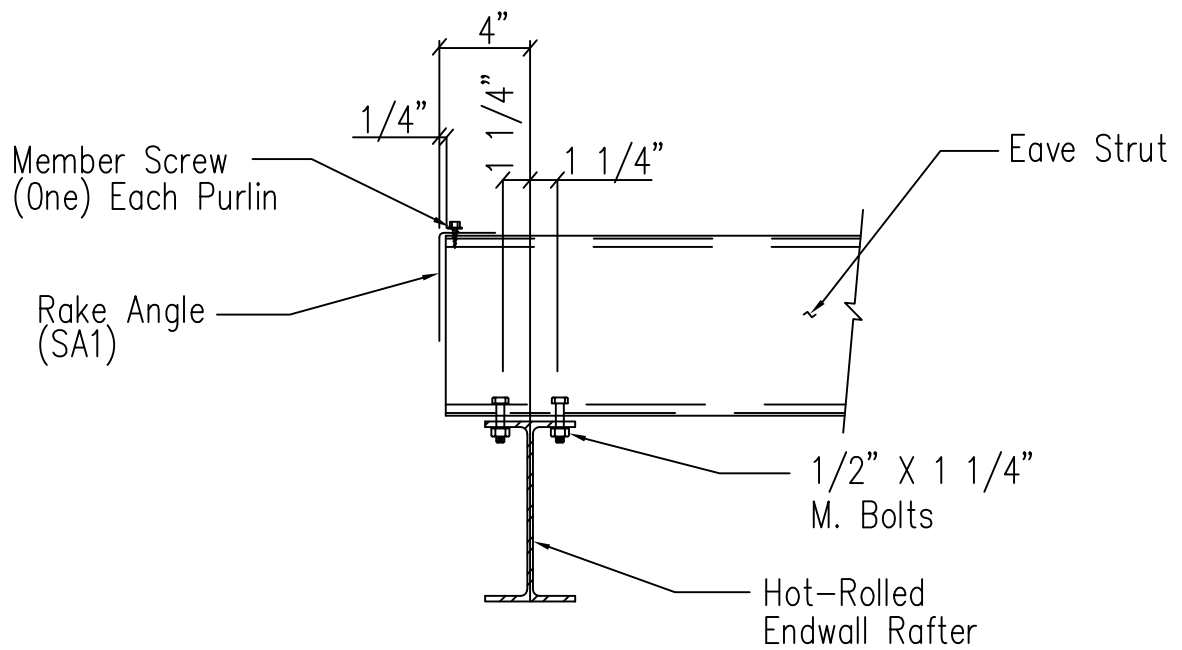
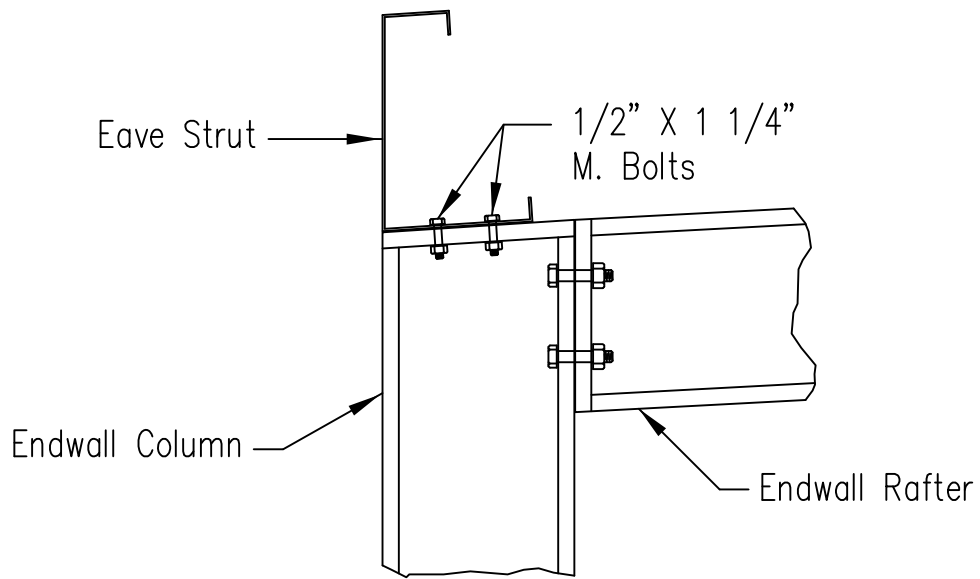

Corner Column Connection WF Rafter/Column
Flush Sidewall

DRAWING NO.
SD12

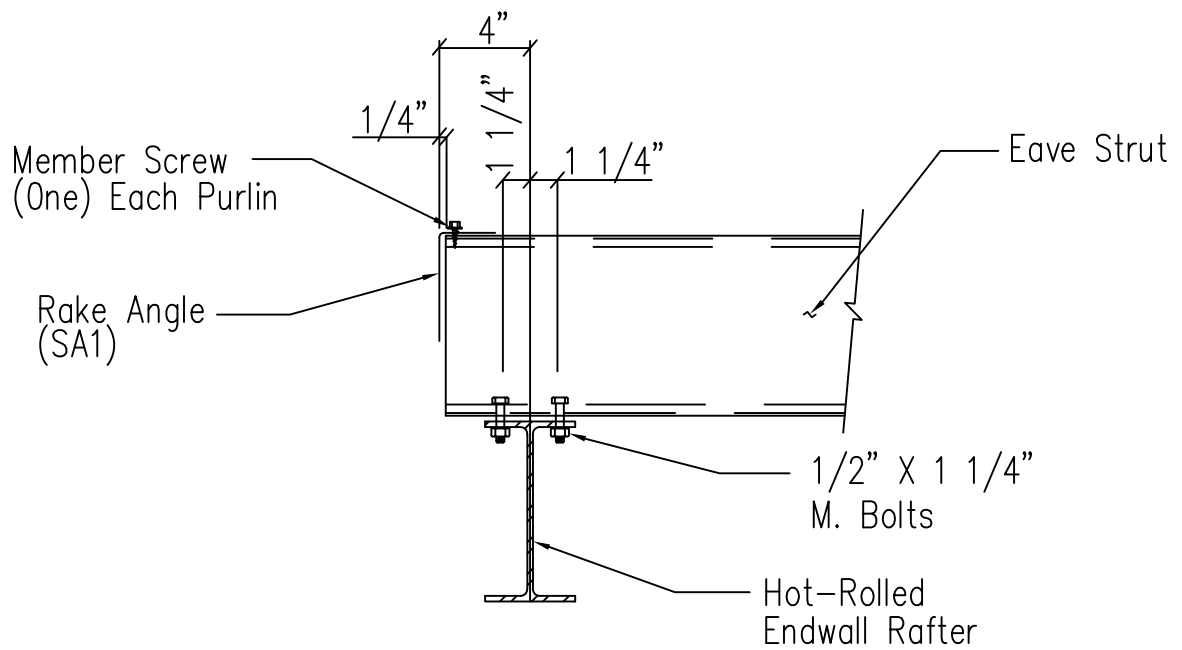
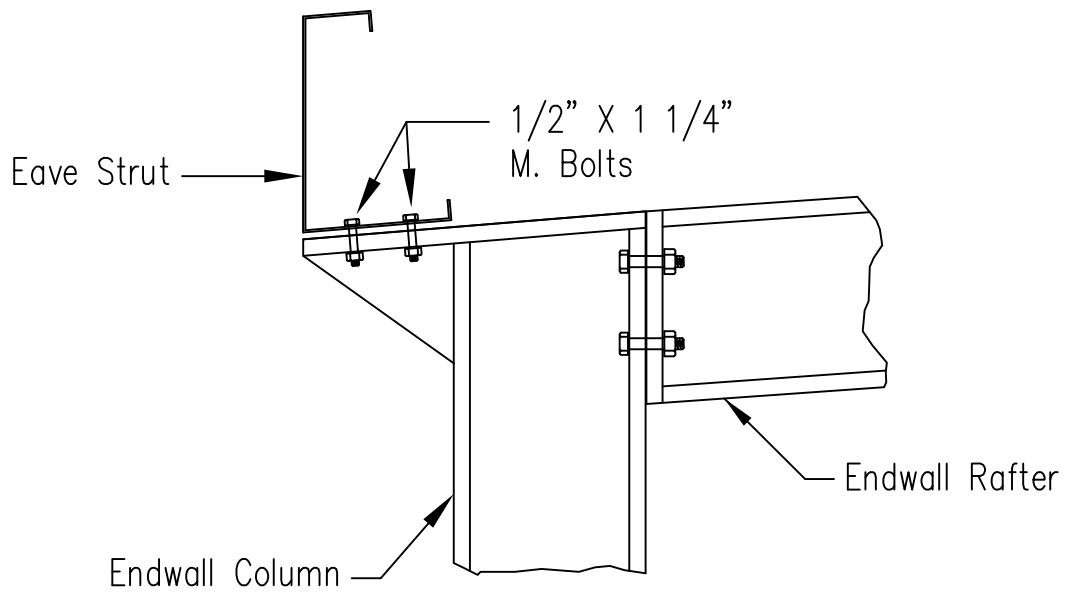

Corner Column Connection WF Rafter/Column
By-Pass Sidewall

DRAWING NO.
SD13

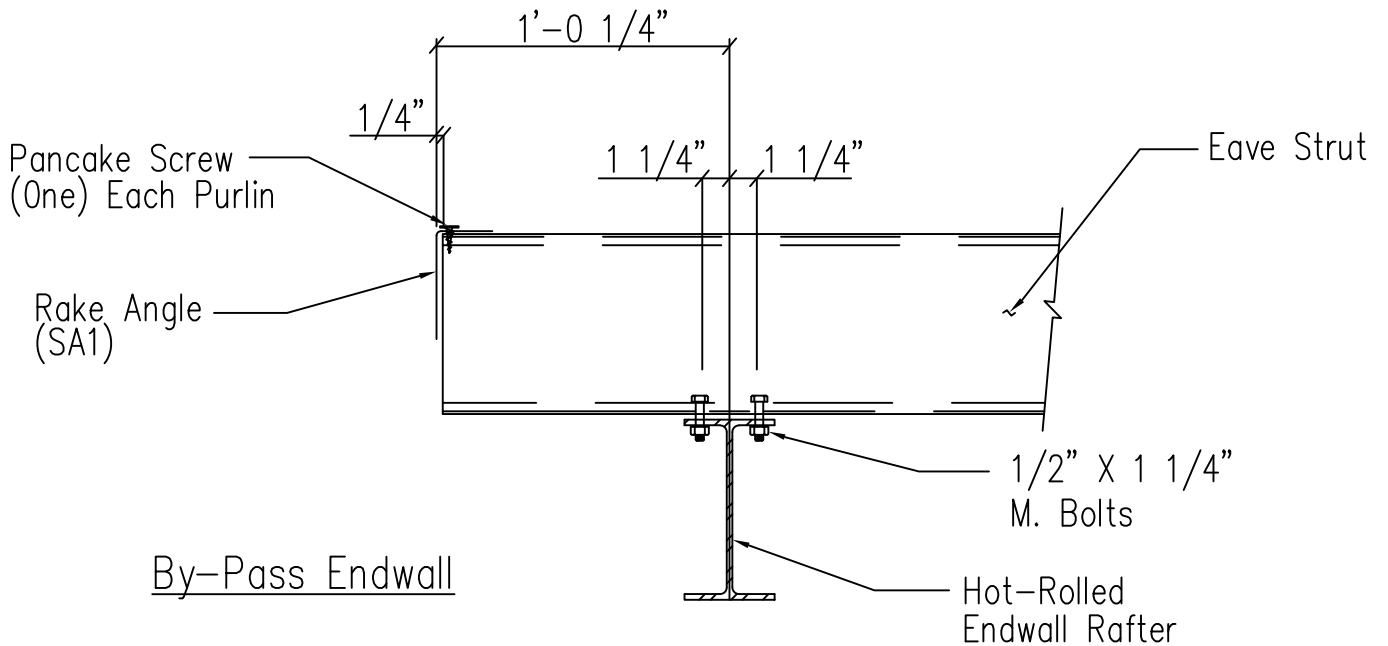
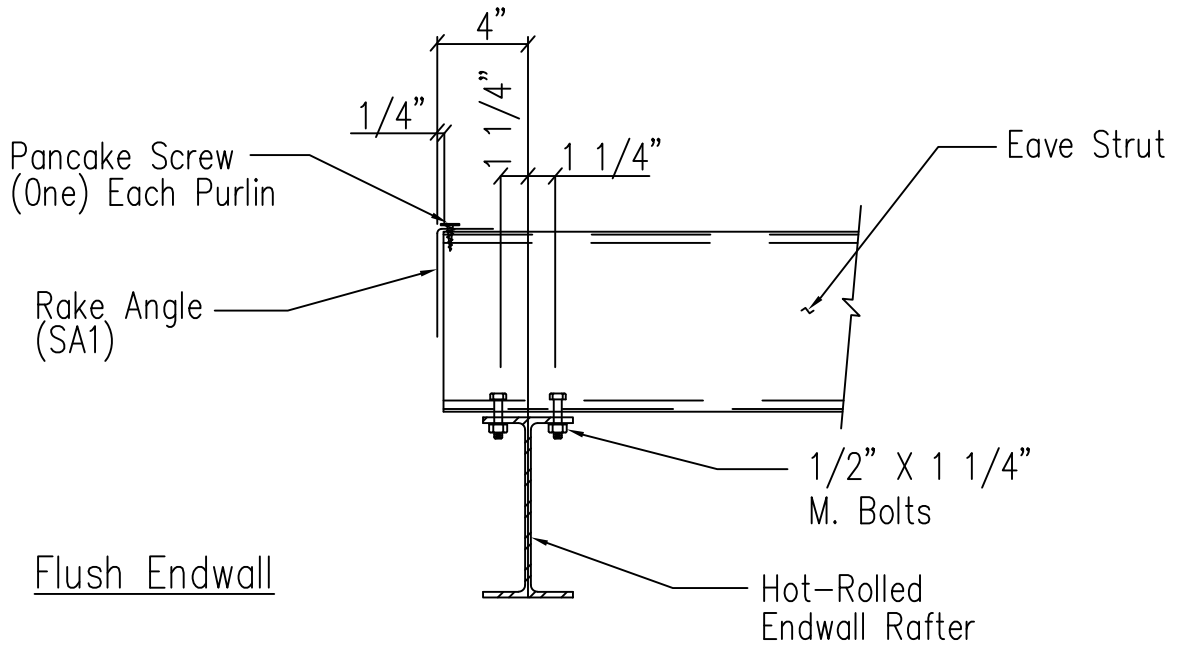

Eave Strut to Hot Rolled Rafter Connection

DRAWING NO.

SD14

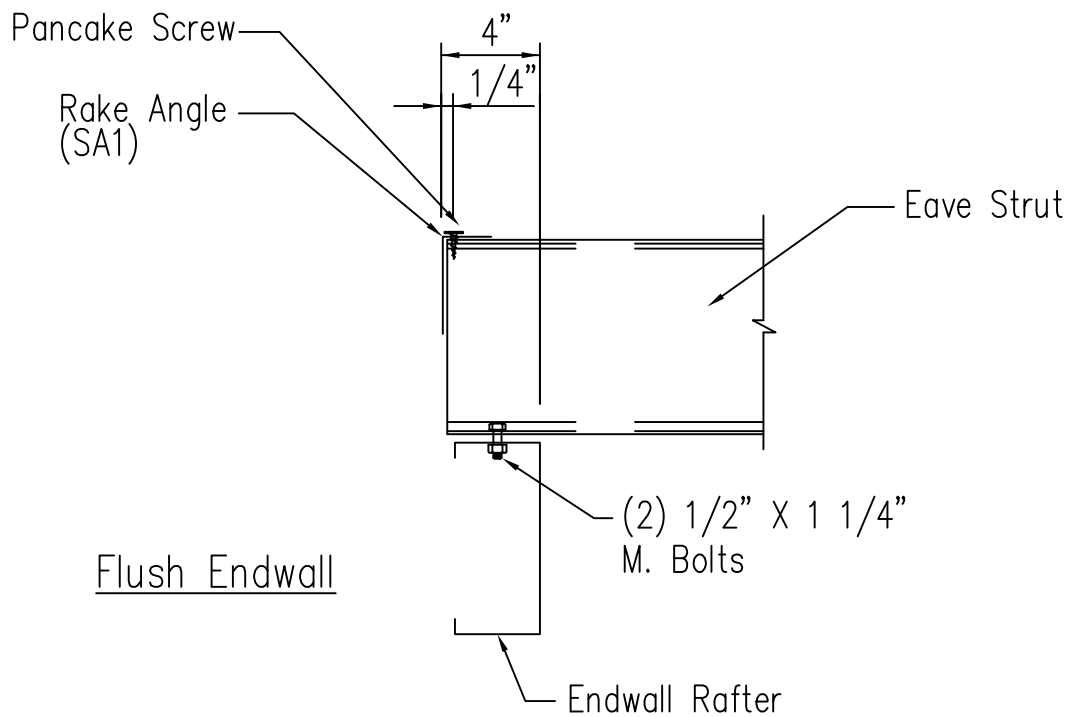
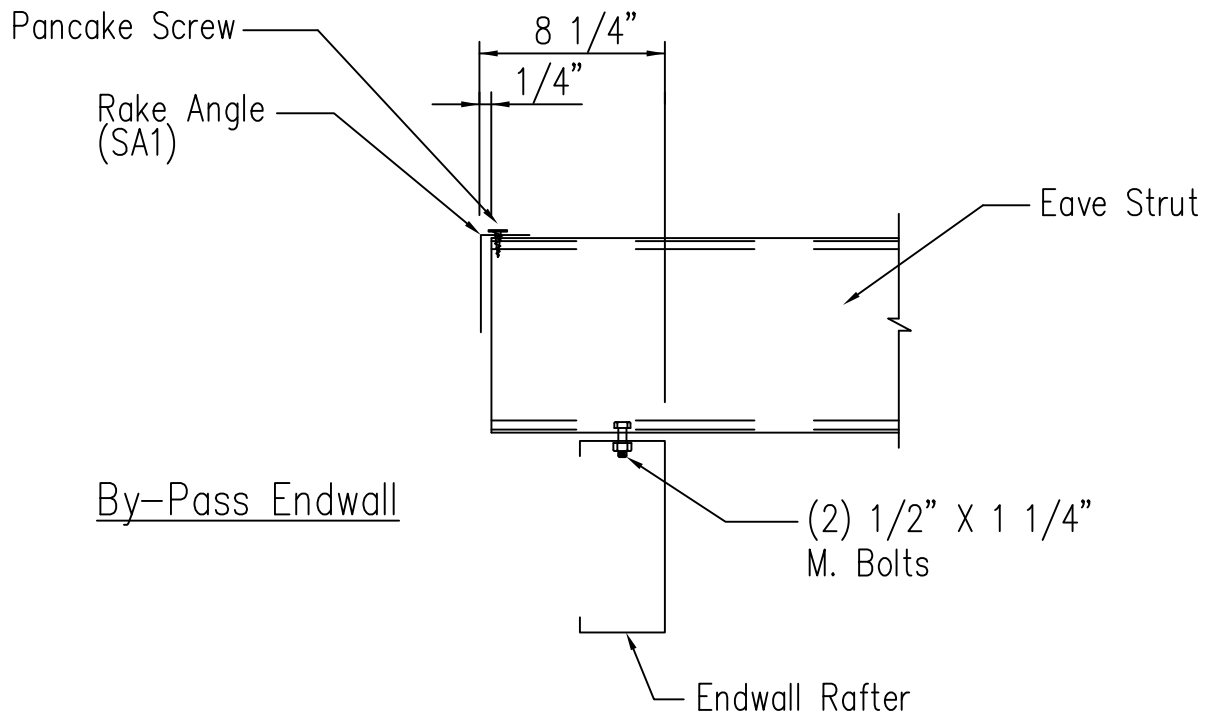

Eave Strut to Cold Form Rafter Connection

DRAWING NO.

SD15

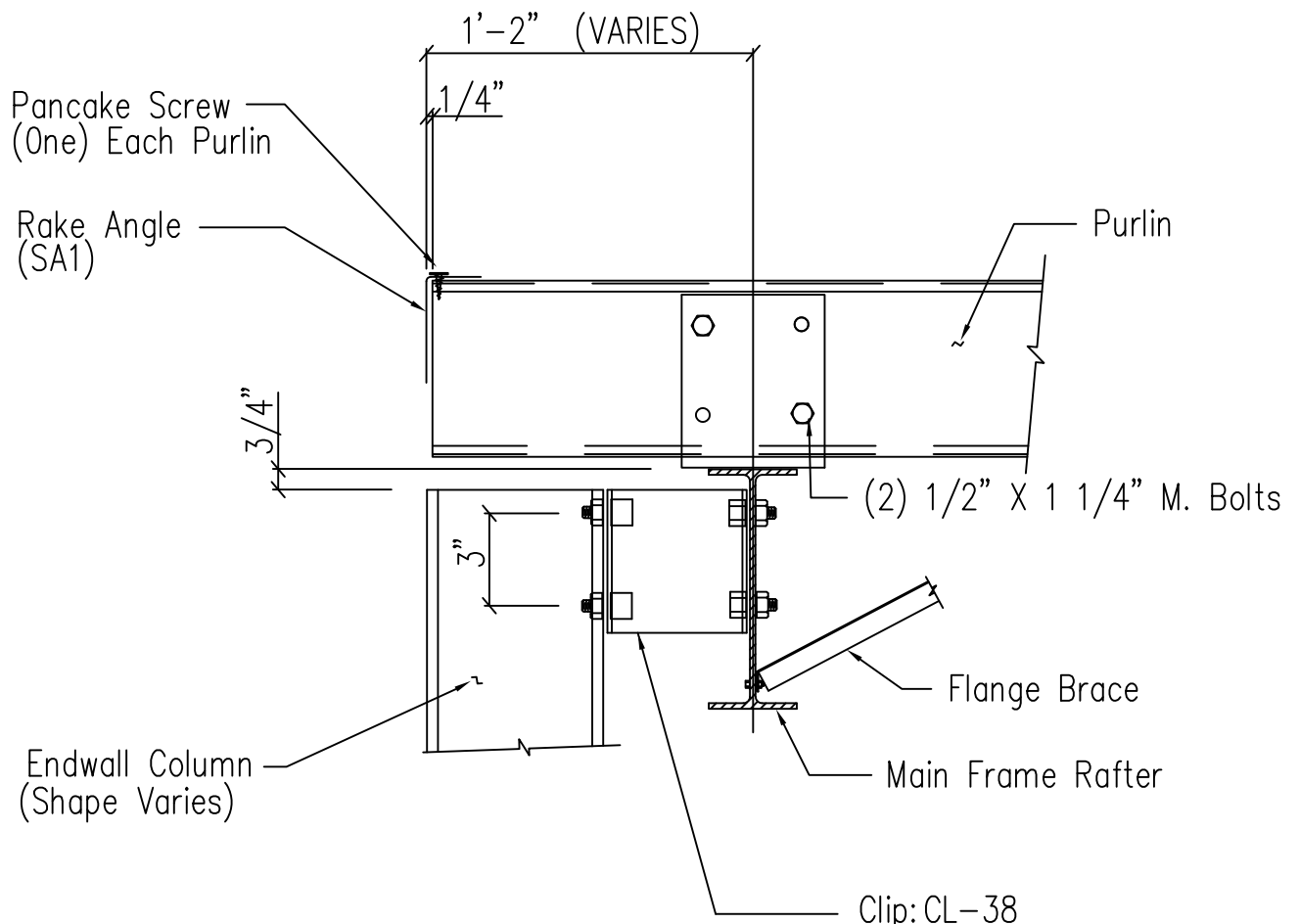

Pancake Screw
(One) Each Purlin

Rake Angle
(SA1)

Purlin

(2) 1/2" X 1 1/4" M. Bolts

Endwall Column
(Shape Varies)

Flange Brace

Main Frame Rafter

Clip: CL-38
5/8" ϕ A325 Bolts
(See Endwall Elevation
For Quantity & Length)

5/8" ϕ A325 Bolts
(See Endwall Elevation
For Quantity & Length)

Main Frame Rafter

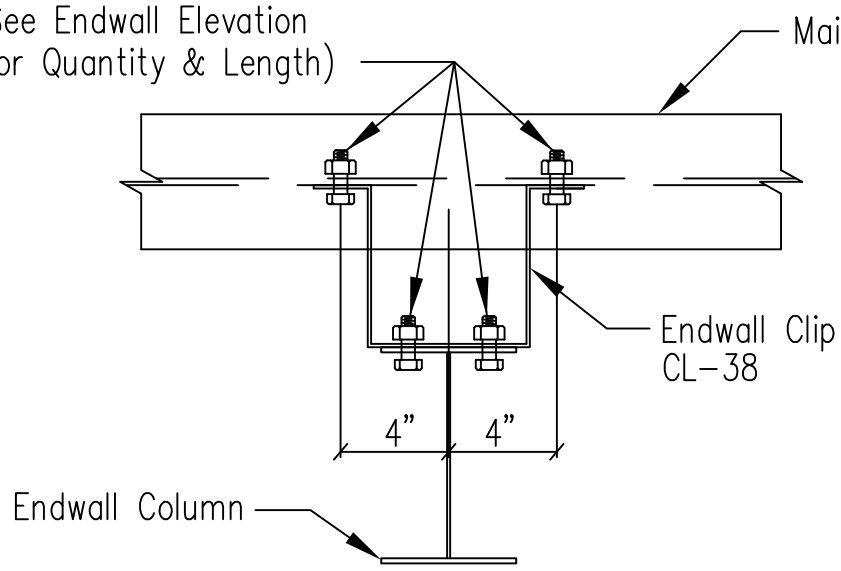

Endwall Clip
CL-38

Endwall Column

WF Column to Main Frame Rafter Connection
Flush Endwall

DRAWING NO.
SD20

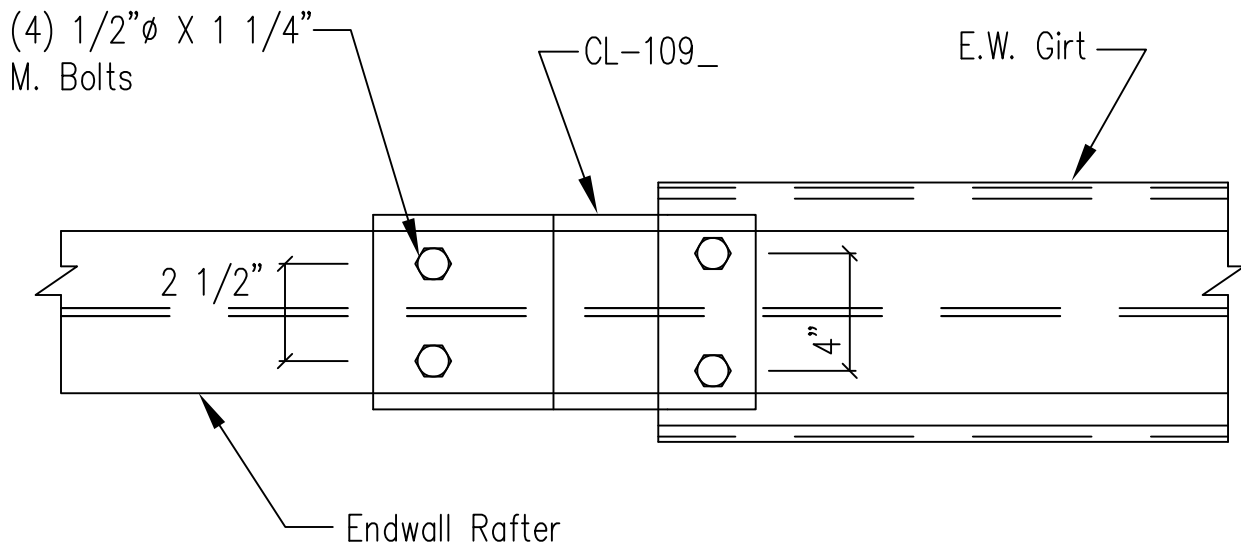
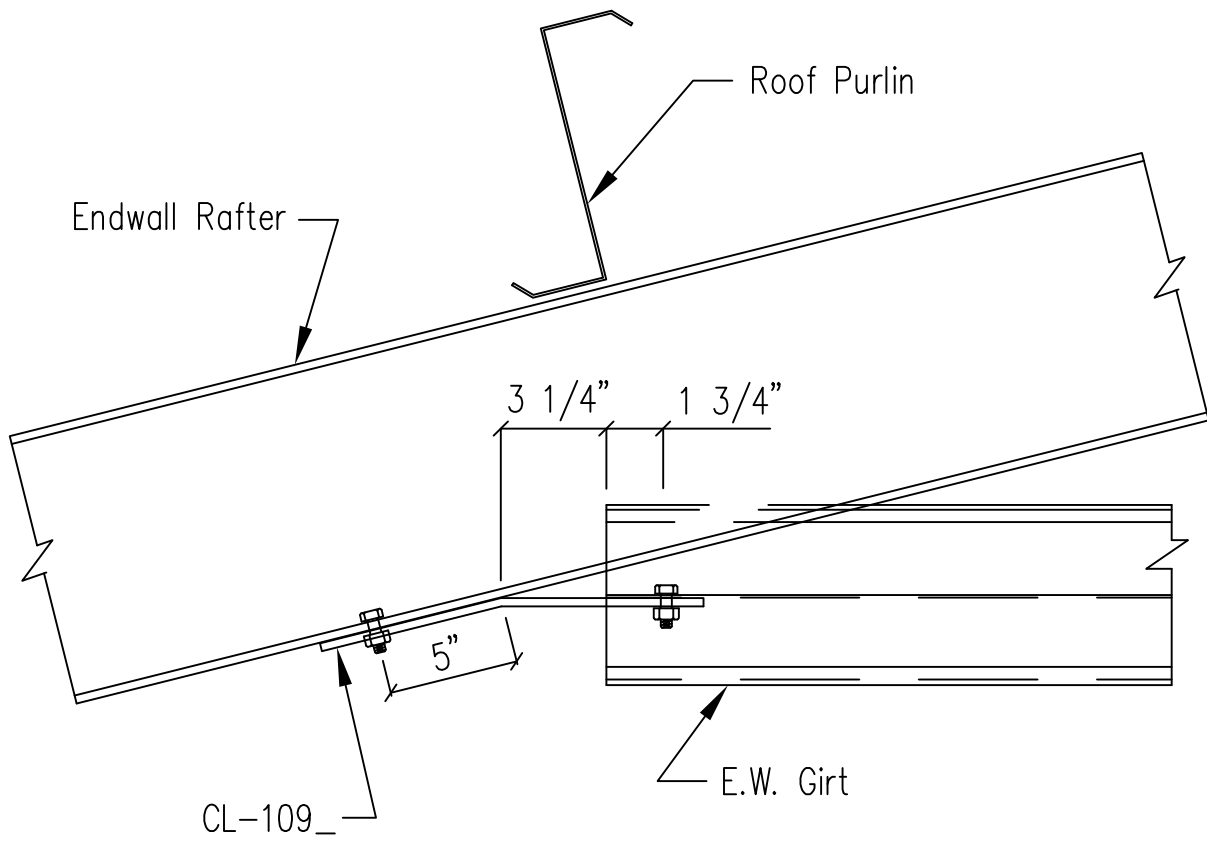

Endwall Girt to Hot Rolled Rafter

DRAWING NO.

SD45

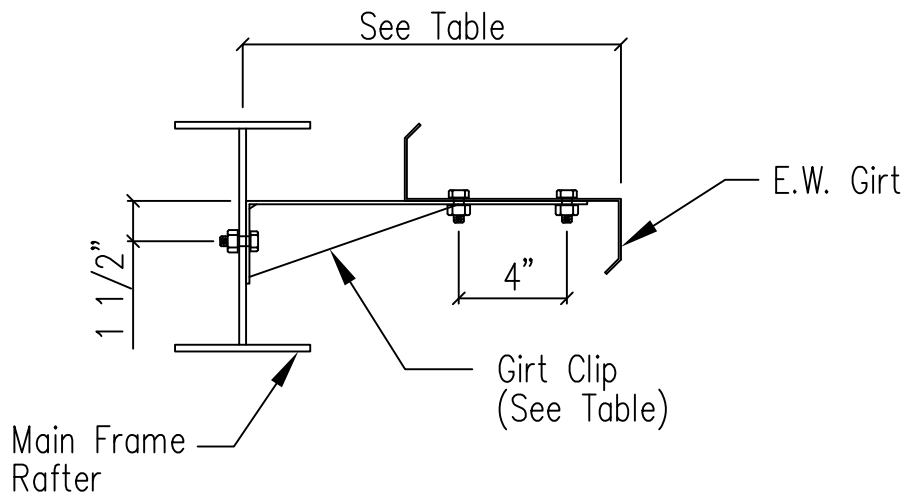
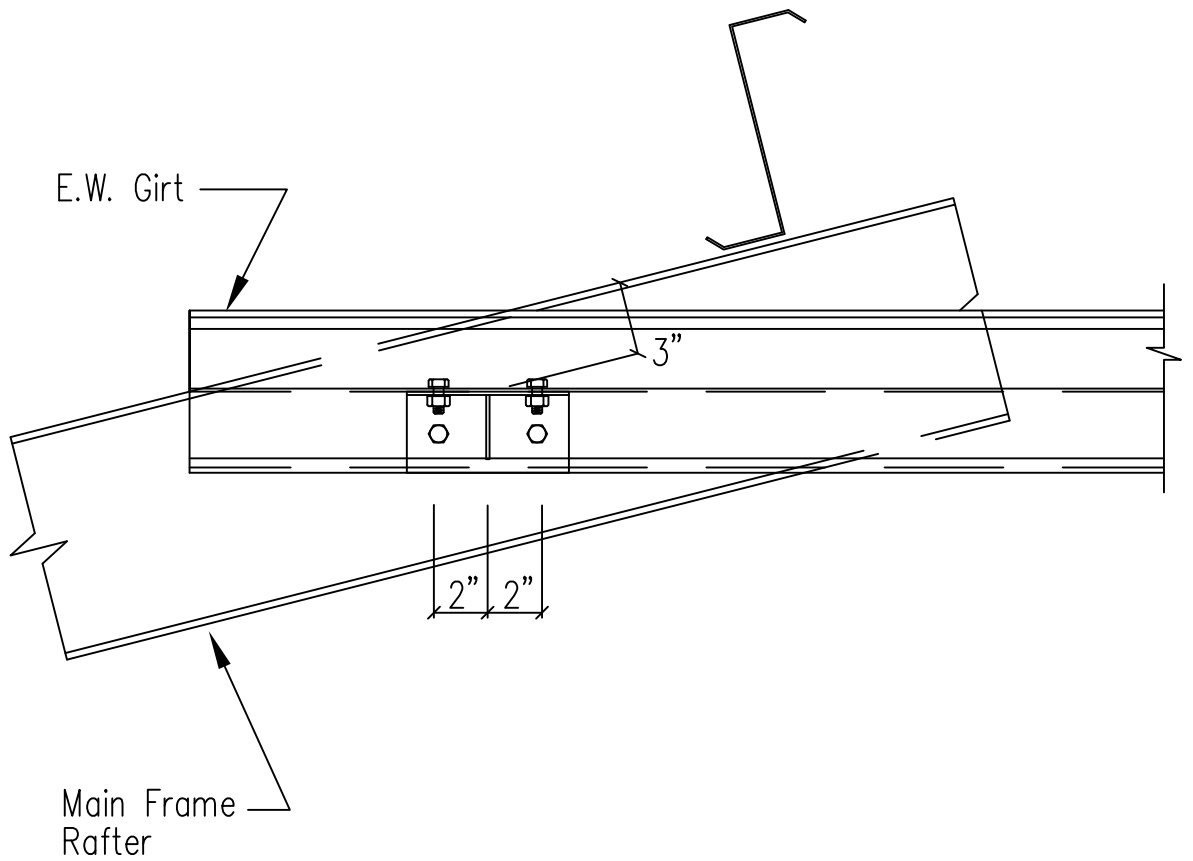

GIRT DEPTH	CLIP	DIMENSION
8"	CL-107	1'-2"
10"	CL-108	1'-2"
1'-0"	CL-107	1'-4"

All Bolts are 1/2" x 1 1/4" A307 Bolt

Endwall Girt to M.F. Rafter

DRAWING NO.

SD46

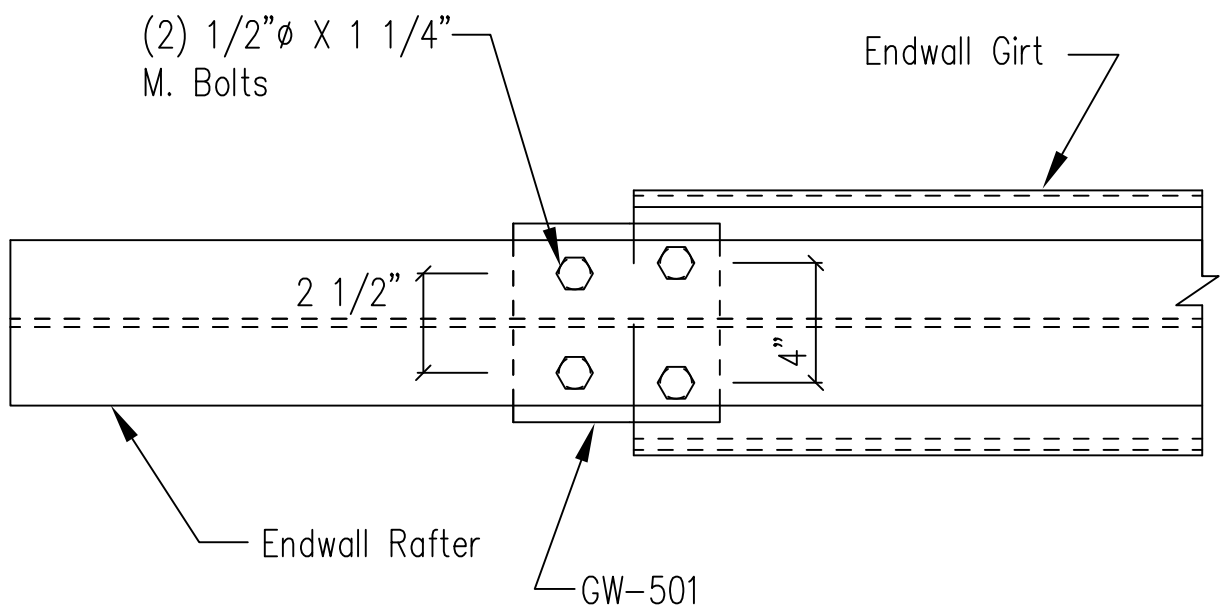
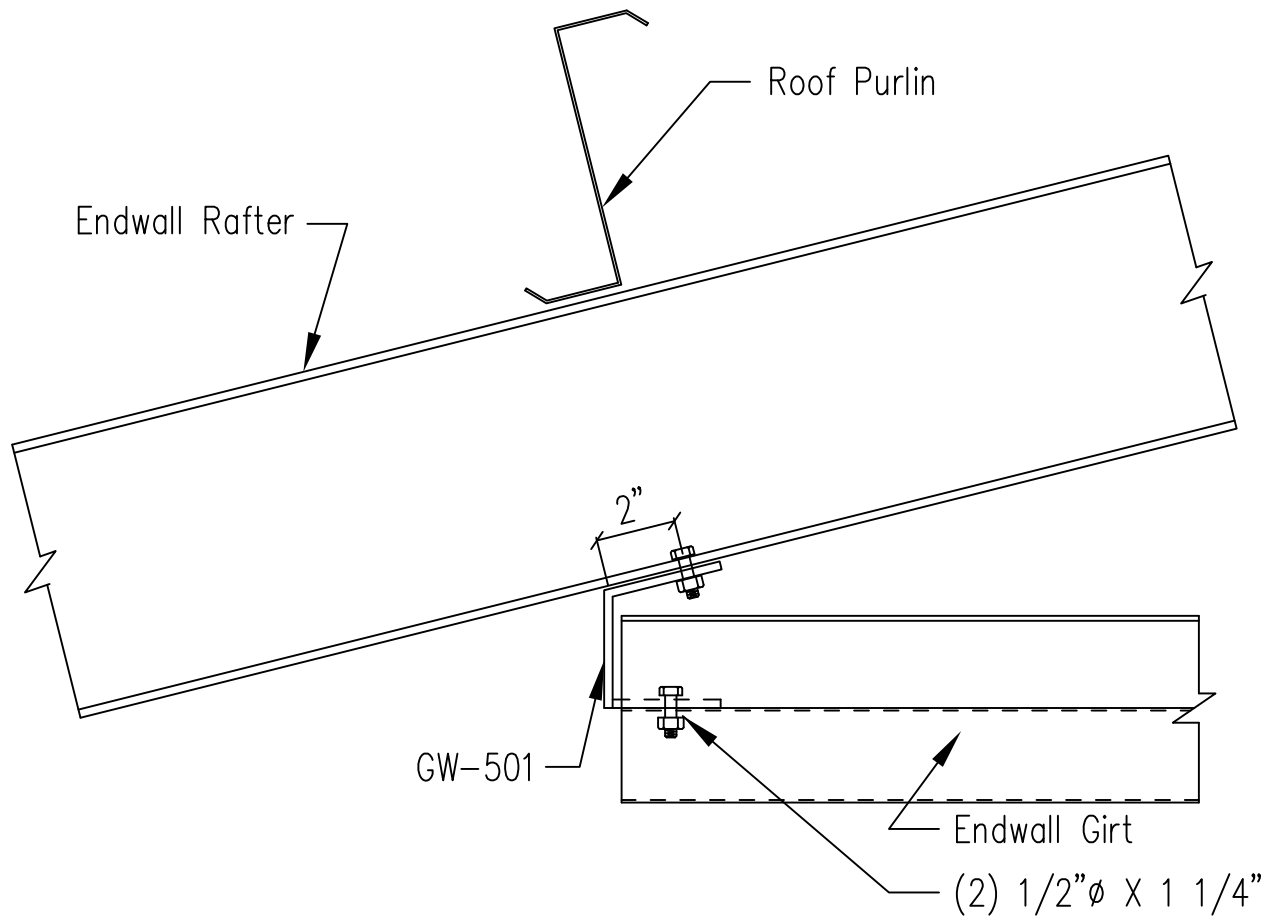

Girt to Rafter

DRAWING NO.

SD46

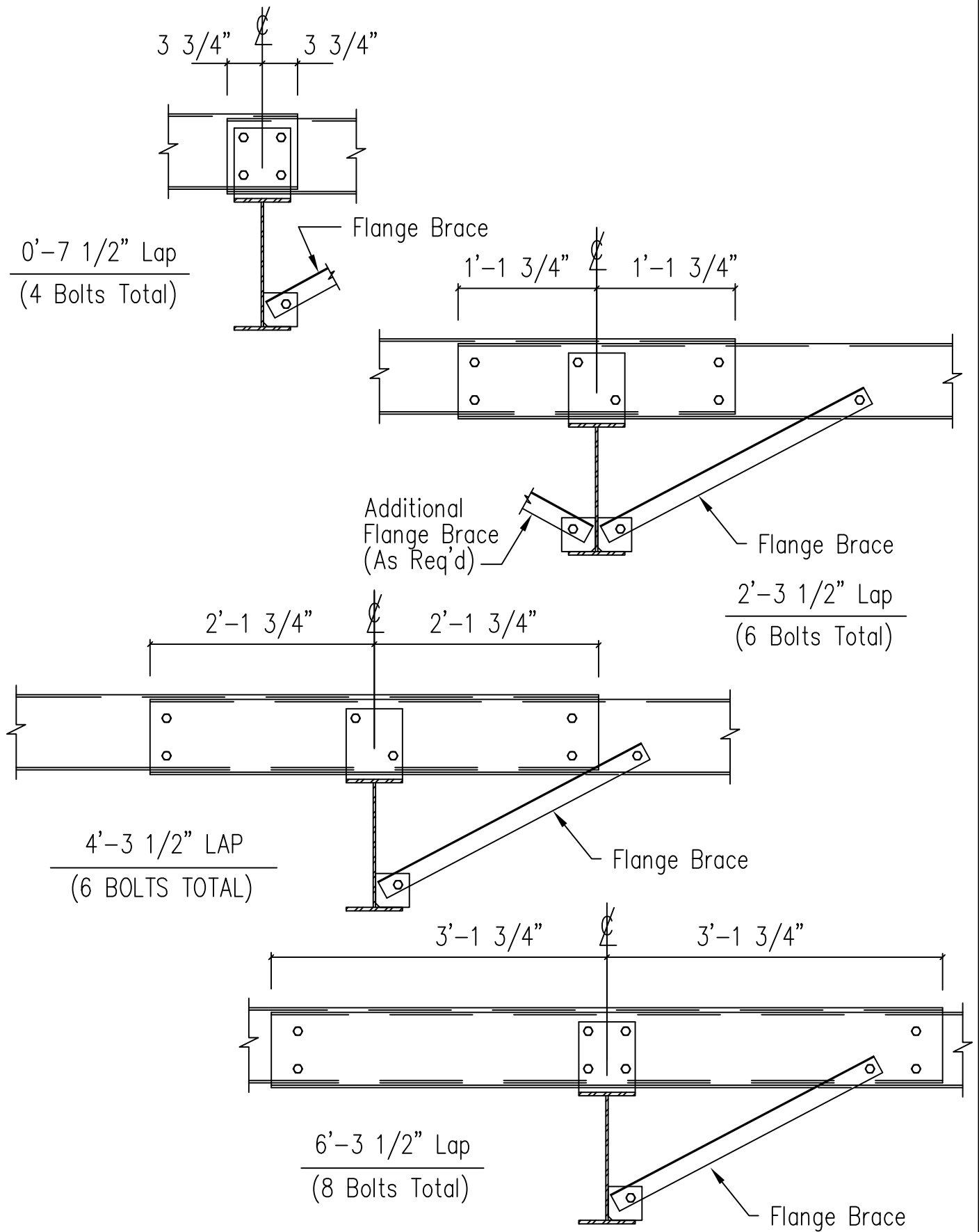

Note: All connection bolts are 1/2" x 1 1/4" machine bolts unless noted.

Interior Bay Purlin Framing

DRAWING NO.

SD50